

Tommy Baumann, David Hipkins, John Mester

The System Design Tool MLDesigner

- Is the leading modeling and simulation tool for design of networked systems
- Automates the design process from mission requirements to implementation handoff
- Is a multi-domain simulator, that combines modeling and simulation capabilities found in various design tools
- Although MLDesigner supports bottom-up design, it is designed for top-down design, iterative design process (sometimes called a spiral design process)

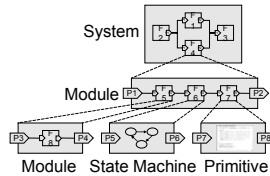
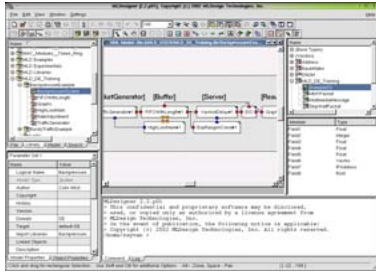

- Black box principle
- Hierarchical decomposition
- Domain combination
- Reusable model elements

The Satellite Environment Tool SatLab

- Is a tool for mission and system level design, animation, and analysis of mobile/satellite communication and navigation systems
- Provides a simulation engine with the fast orbital propagator and trajectory generator for mobiles (aircrafts, missiles, cars, etc..)
- Provides an animation system with views from space, from earth and in 3D terrain, coverage analysis, circle views and path loss view in 3D terrain
- Contains a terrain data base system, compatible with USGS DEM, USGS Land Usage data, and DMA DTED data
- Contains the high-level programming language SatLab Command Language (SCL)

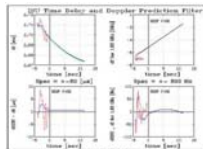
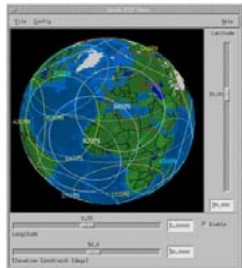

- Satellites with either circular or elliptical orbits
- Fixed earth stations at any latitude, longitude and altitude
- Mobile earth stations
- Parameters to define all system parameter values

Extended Mission Level Design Flow

- Efficiency of tools grows maximum 25% per year while complexity of electronic systems grows 65% per year
→ **System Design Gap**
- Increasing abstraction widens discrepancy between design and implementation
→ **System Abstraction Gap**
- Finding appropriate design regarding increasing count and complexity of requirements
→ **Design Space Exploration**
- **Improving quality and speed of specification**

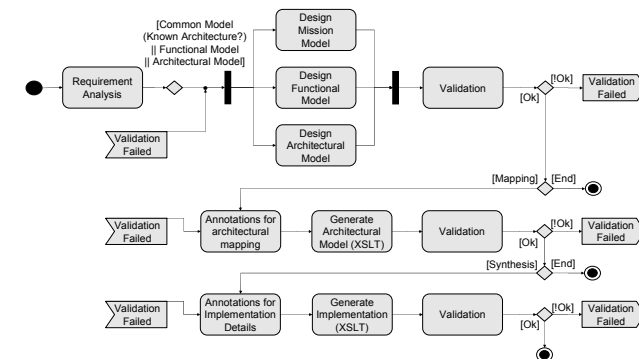
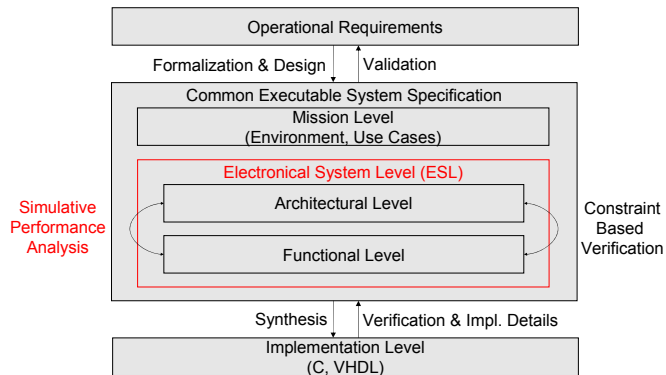

Specification of STEP

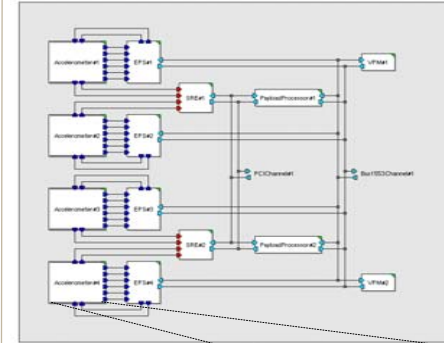

- Design of an executable, model based specification of STEP
- Common description of environment, function and architecture
- Multi-domain approach (CTDE, DE, SDF, FSM)
- Figure: Architecture/ Performance Level (DE)
- Design of Payload and Service module
- Integration of PCI and 1553 protocols

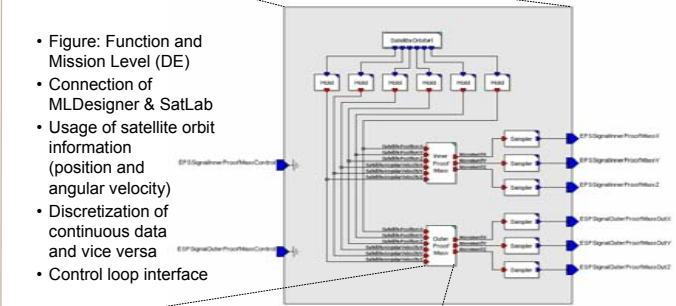

- Figure: Function and Mission Level (DE)
- Connection of MLDesigner & SatLab
- Usage of satellite orbit information (position and angular velocity)
- Discretization of continuous data and vice versa
- Control loop interface

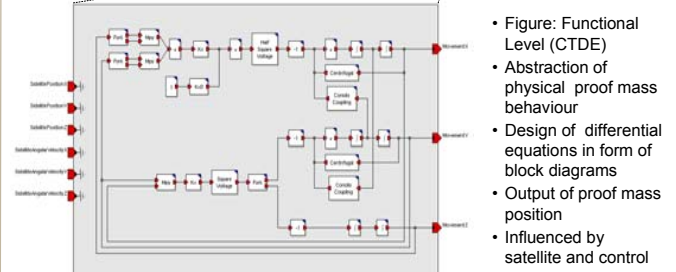

- Figure: Functional Level (CTDE)
- Abstraction of physical proof mass behaviour
- Design of differential equations in form of block diagrams
- Output of proof mass position
- Influenced by satellite and control