

Photographic Lenses

Content

08.07.2008

1. Overview
2. General description
3. Singlets
4. Petzval Lenses
5. Anastigmatic Doublets
6. Triplets, Quadruplets
7. Quasi-Symmetric Wide-field, Wide-Angle
8. Telephoto, Retrofocus
9. Fish-eye
10. Special
11. Vignetting, Stopping down
12. Straylight and Ghost Images

Photographic Lenses Overview

- Families of photographic Lenses
- Long History
- Not unique

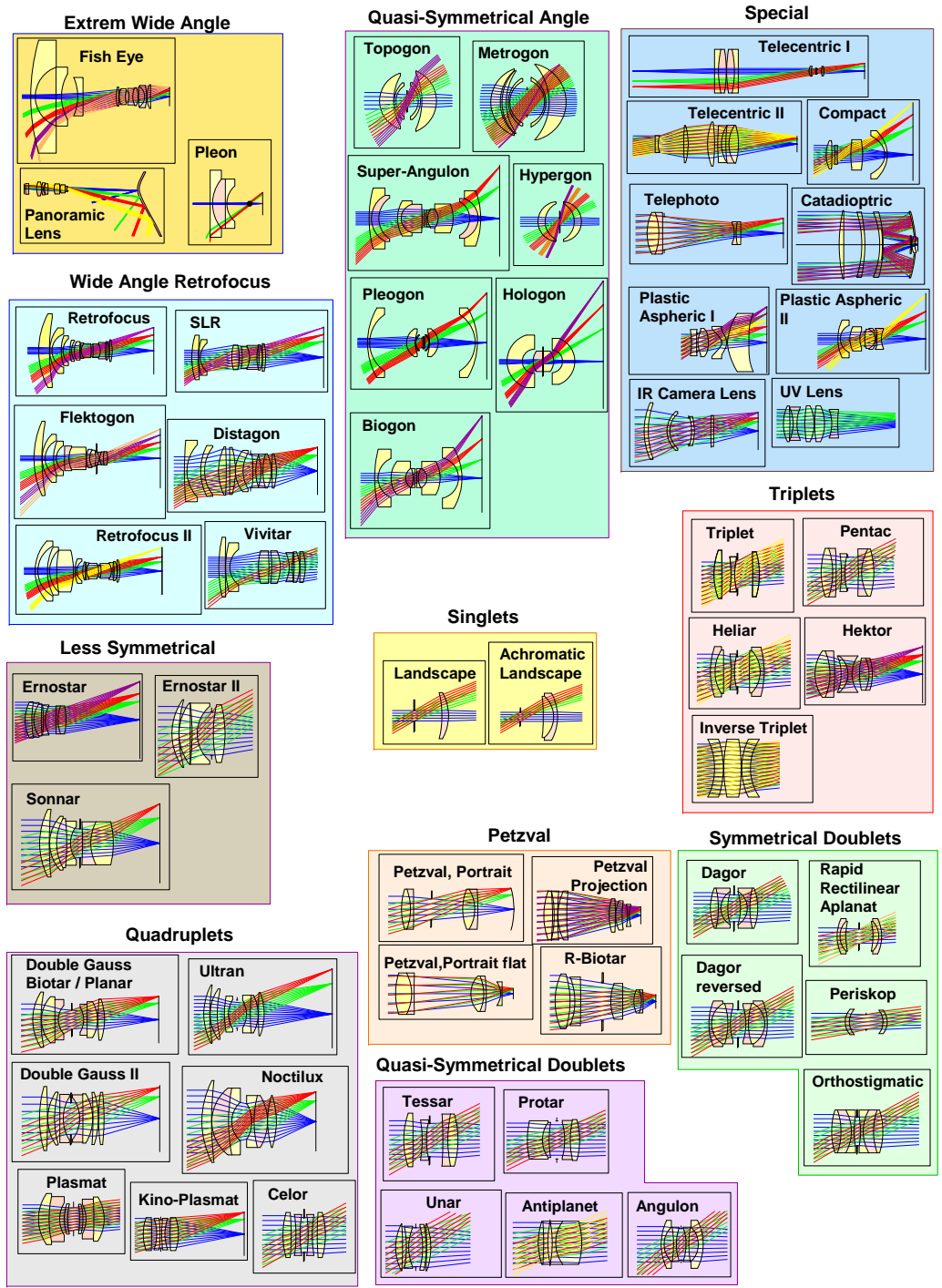

Photographic Lenses

Anforderungen

1. Korrektur von Verzeichnung, Koma, Wölbung und Astigmatismus über ein i.A. großes Feld
2. Farbtreue Bildwiedergabe → Korrektur von Farbfehler, insbesondere Farbquerfehler (max. 1-2 Pixel für digitale Sensoren)
Korrektur der sphärische Aberration über die Wellenlänge
3. Auflösung feiner Details
Film: Begrenzung Korngröße des Films (max. 100 LP/mm)
CCD: Begrenzung Pixelgröße des Sensors (etwa $\frac{1}{2}$ Nyquist-Frequenz)
4. Hohe Öffnung
→ dunkle Szenen
5. Kompakte und leichte Bauform
→ Kurze Baulängen, Linsen dicht gestellt
Einsatz von Kunststoffkomponenten
6. Ergänzende Funktionen
Zoom, Autofokus, Suchereinblick



Photographic Lenses

Field Size and Aperture

- Apertures:

- 1. low aperture : f/14
- 2. medium aperture : f/6 ...f/8
- 3. high aperture : f/2.8 ...f/1.0

Triplet
Tessar
Double Gauss

- Typically Field sizes

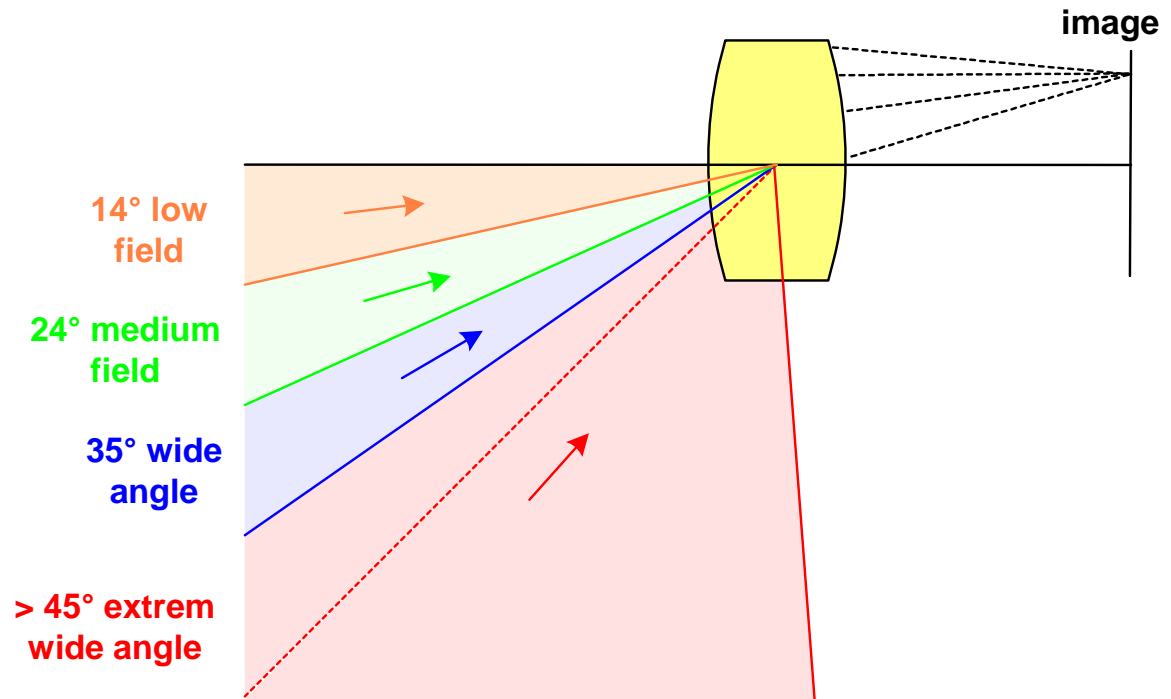

Photographic Lenses

Field Size and Aperture

Typical ranges

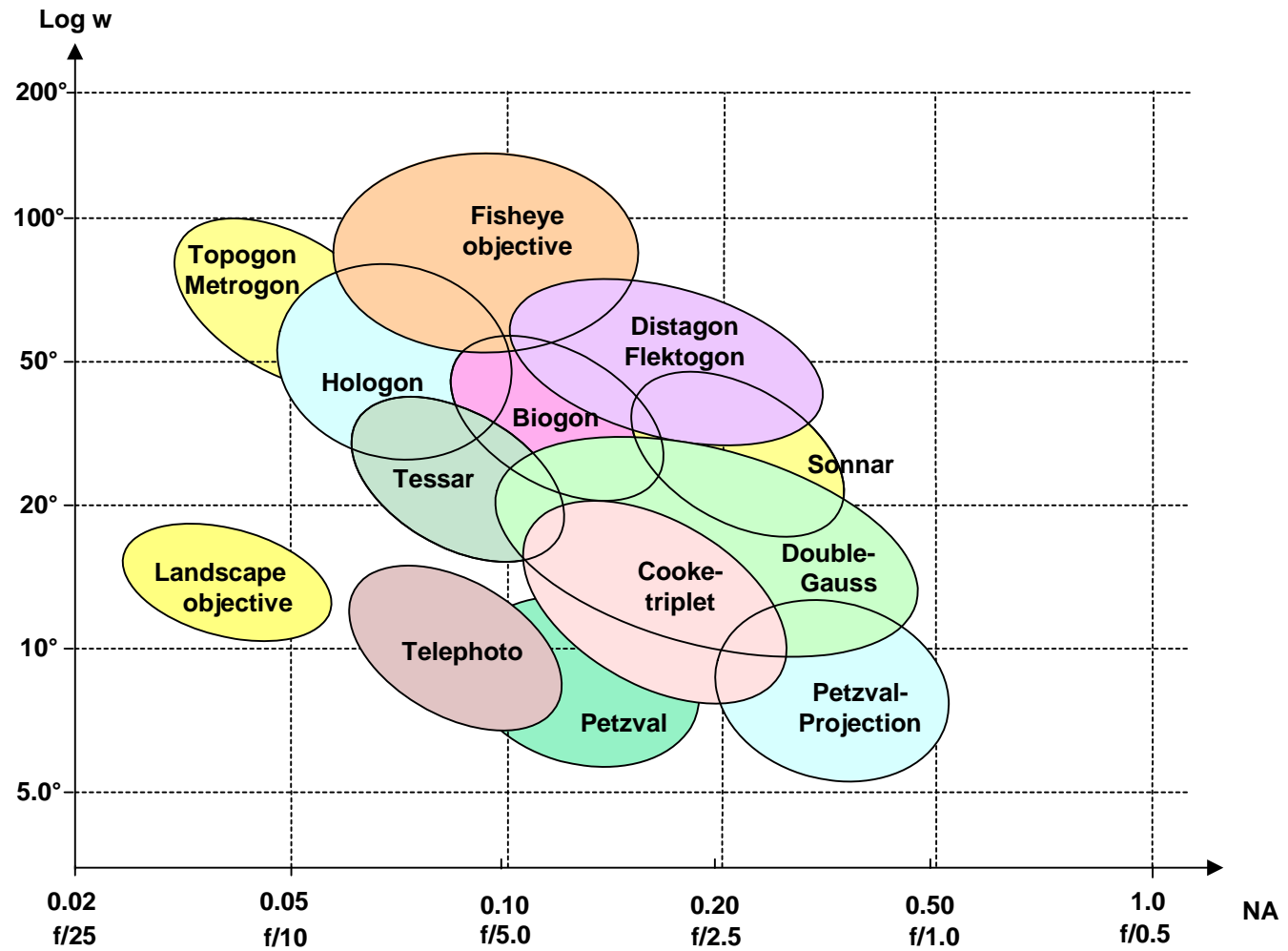

Photographic Lenses

Image Format

- Standard sensor Formats

name of the format	size in mm x mm	length of the diagonal in mm
8 mm	3.52 x 4.8	5.95
Super 8	4.22 x 5.77	7.15
16 mm	7.42 x 10.22	12.63
35 mm movie	19.05 x 25.37	31.73
35 mm still	24 x 36	43.3
6 x 7	56 x 69.5	89.3
4 x 5	101.6 x 127.0	163
CCD 1/2 inch, aspect 4:3	4.80 x 6.40	8.00
CCD 2/3 inch, aspect 4:3	6.60 x 8.80	11.00
CCD 1 inch, aspect 4:3	9.60 x 12.8	16.00

- Pixel numbers

name of the format	pixel grid
CCD VGA	480 x 640
CCD SVGA	768 x 1024
CCD HDTV	1080 x 1920
35 mm still movie	8400 x 12600
6 x 7	19600 x 24325

Photographic Lenses

Focal Lengths and Formats

		135 mm film	Cut film 9x12	Rollfilm 6x6	Advanced Photo System 3:2	Digital 3:2 1"	Digital 4:3 2/3"	Digital 4:3 1/2"	Digital 4:3 1/3"
	2x in [mm]	36	112	56.5	25.1	13.8	8.8	6.4	4.8
	2y in [mm]	24	83	56.5	16.7	9.2	6.6	4.8	3.6
	h in [mm]	21.6	69.7	40.0	12.6	8.3	5.5	4.0	3.0
Super wide angle	107°	16	52	30	11	6.1	4.1	3.1	2.1
	100°	18	58	33	13	6.9	4.6	3.5	2.3
	94°	20	64	37	14	7.7	5.1	3.8	2.6
Wide angle	84°	24	77	44	17	9.2	6.1	4.6	3.1
	75°	28	90	52	20	11	7.1	5.4	3.6
Standard	47°	50	160	92	35	19	13	9.5	6.4
Telephoto	29°	85	270	160	59	33	22	16	11
	18°	135	430	250	94	52	34	26	17
	12°	200	640	370	140	77	51	38	26
Super Telephoto	8°	300	970	550	210	120	76	57	39
	2.5°	1000	3200	1800	700	380	250	190	130

Photographic Lenses

Depth of Field

- Circle of least confusion D'_o , F-number k
- Sharp image distances

$$s_{near} = \frac{p \cdot D_{EnP}}{D_{EnP} + D_o} = \frac{p^2 s'}{ps' + ksD'_o} \quad s_{far} = \frac{p \cdot D_{EnP}}{D_{EnP} - D_o} = \frac{p^2 s'}{ps' - ksD'_o}$$

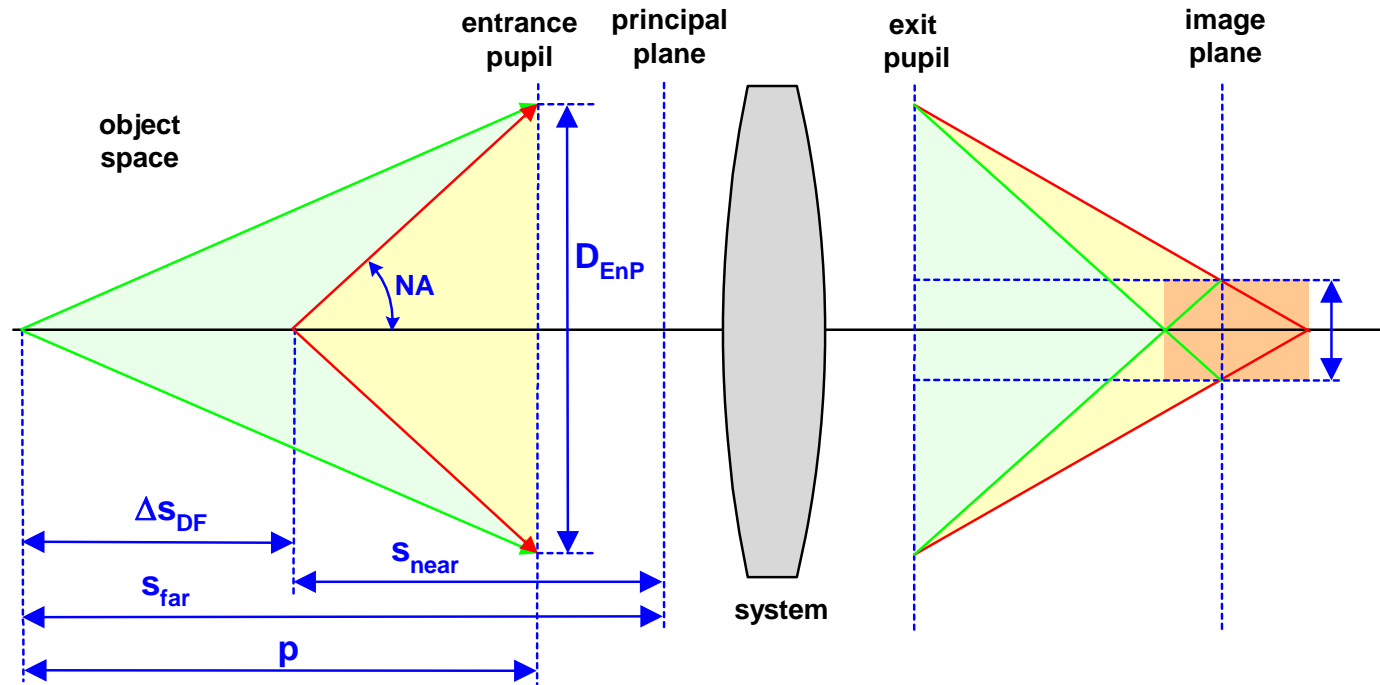

Photographic Lenses

Brightness and Exposure

- Exposure Time corresponds to aperture
- Range between wide angle and telephoto lenses

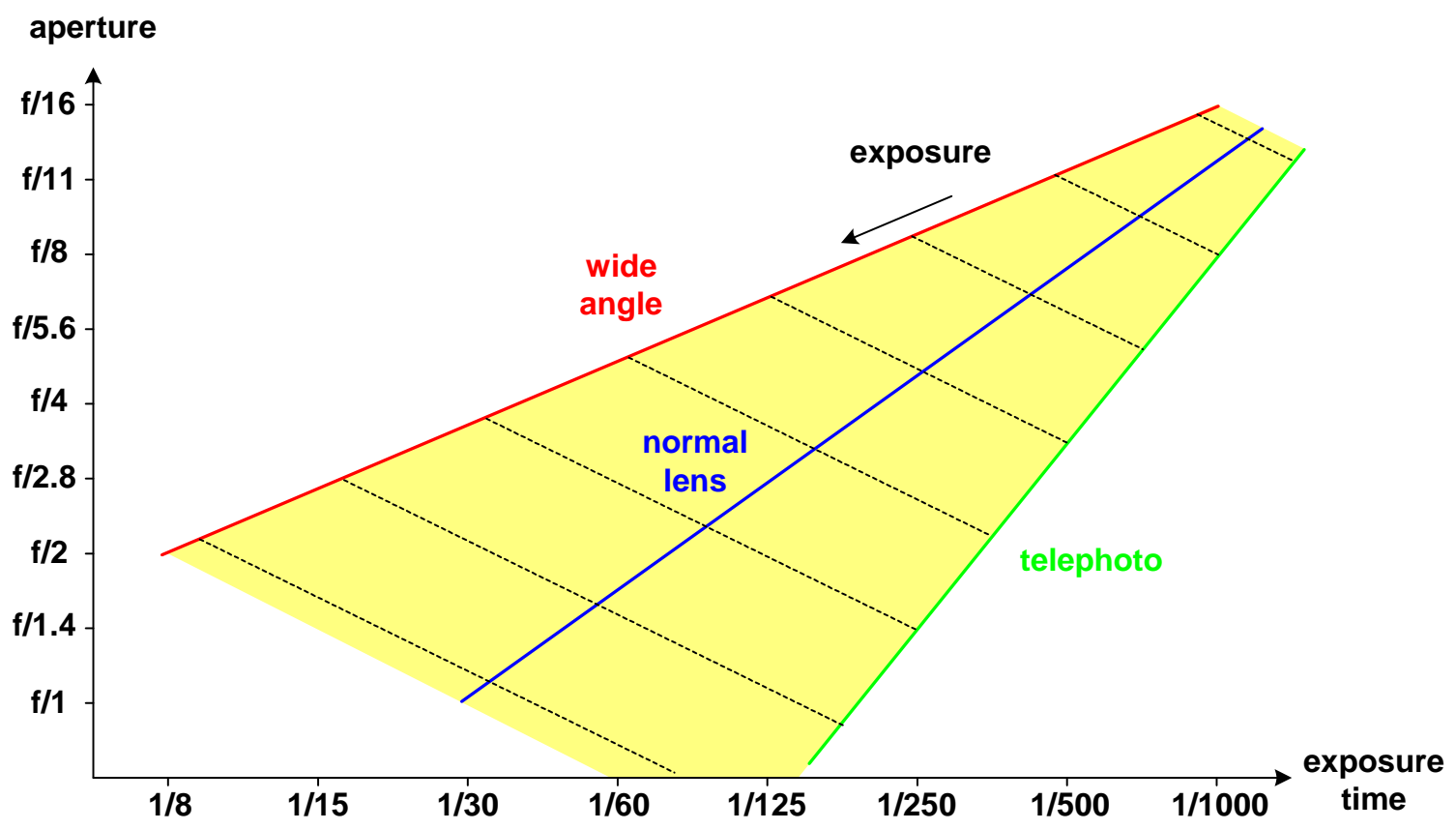

Photographic Lenses

Singlet Lenses

Landscape

- Stop: rear

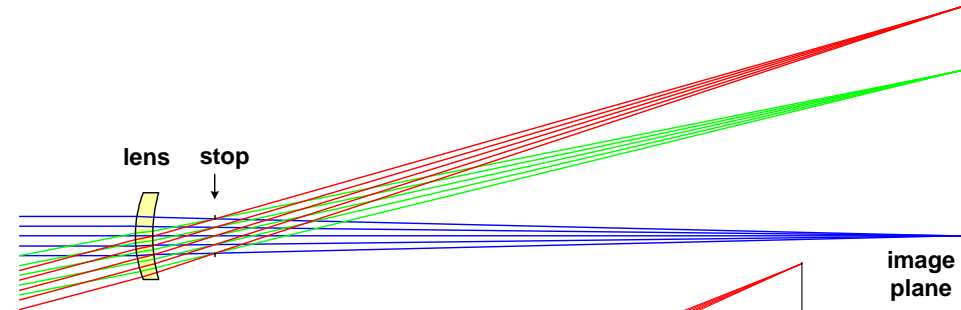

- Stop : front

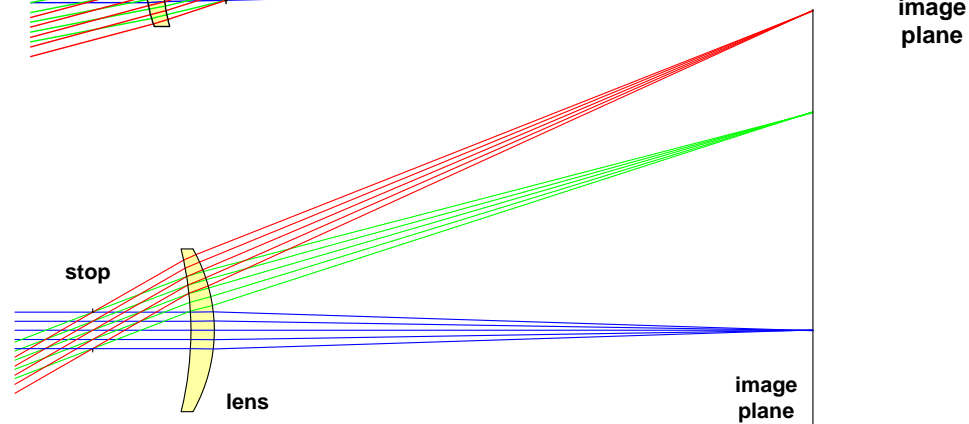

- Achromatic (Chevalier, French, Grubb)

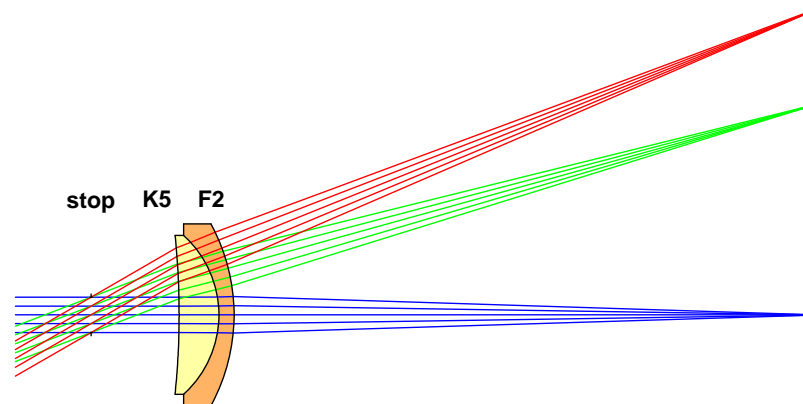

Photographic Lenses

Petzval Lenses

- Petzval Portrait lenses (1840):
2 Achromates

Problems : field curvature
vignetting

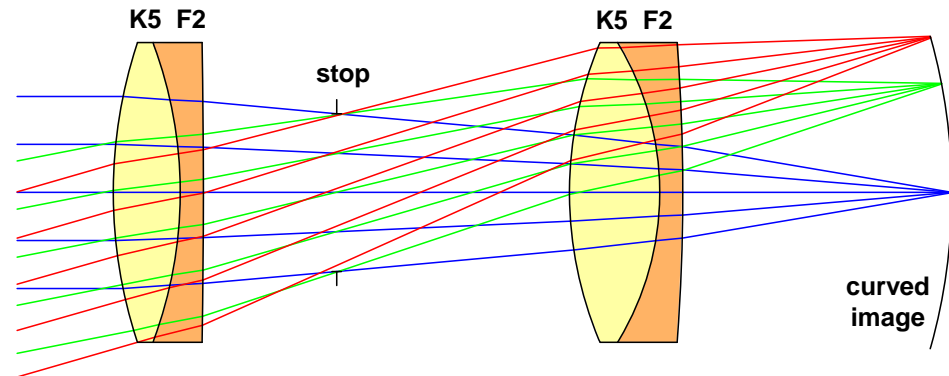

- Version with flattening lens
(1873 by Piazzzi-Smyth)

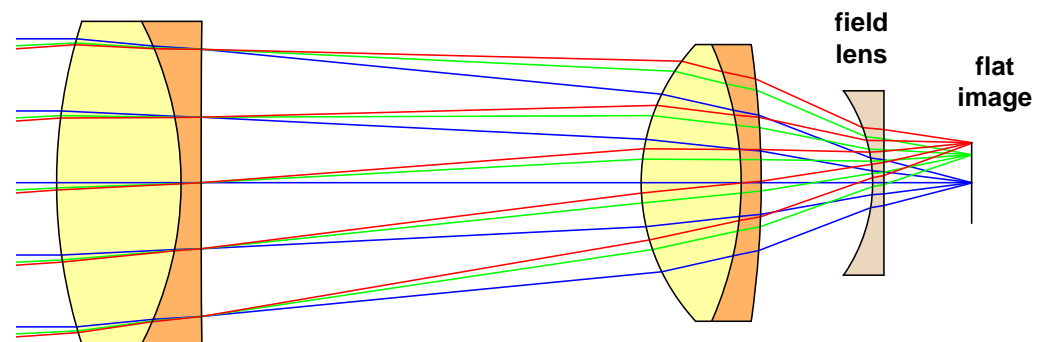

Photographic Lenses

Petzval Lenses

- Typical performance

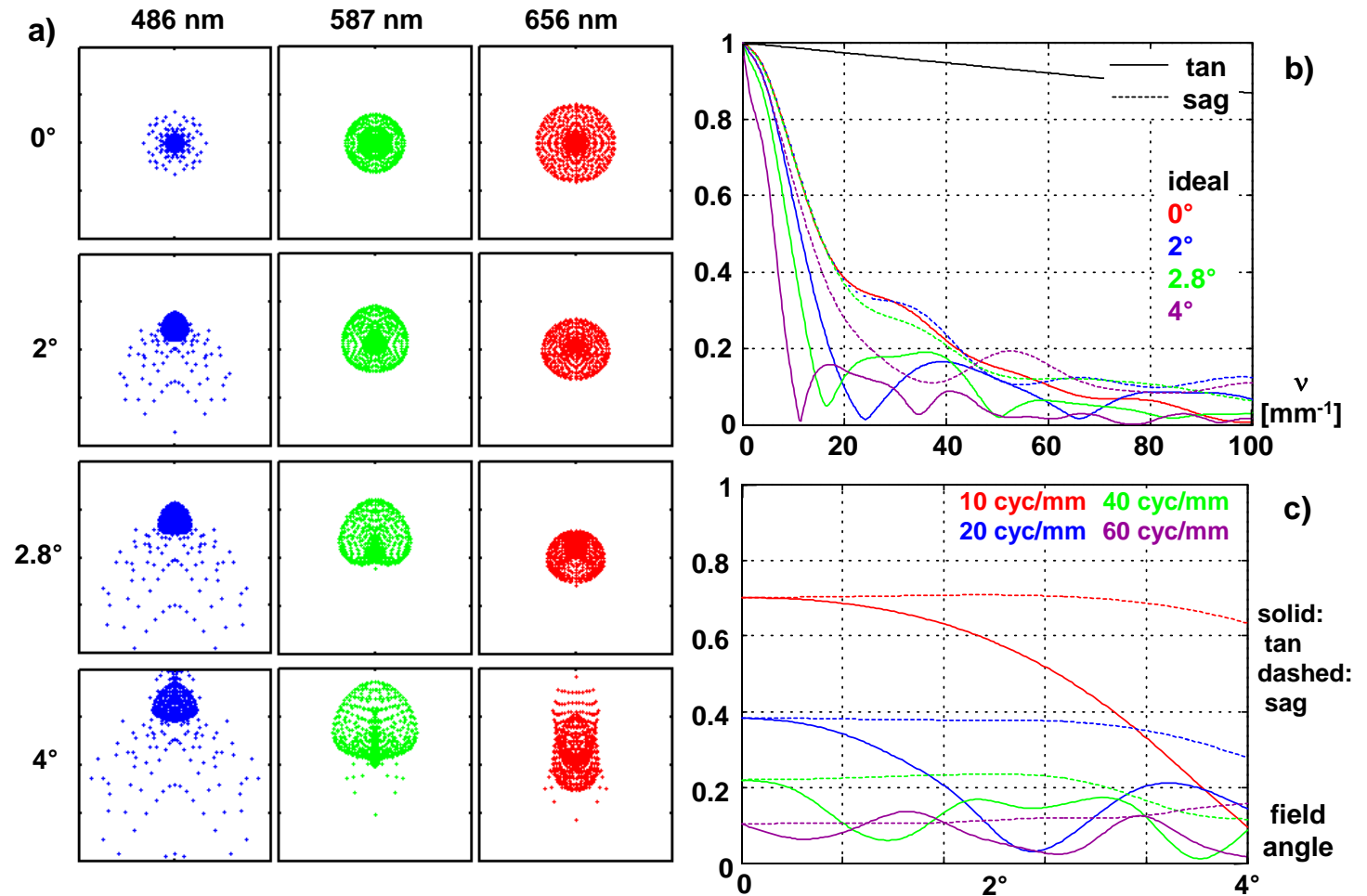

Photographic Lenses

Symmetrical Anastigmatic Doublets

- Steinheil Periscope
 - good correction of distortion and lateral colour due to symmetrical setup

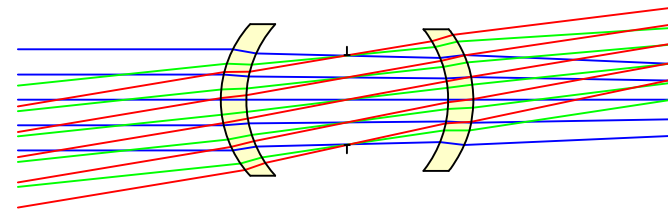

- Rapid Rectilinear (Dallmeyer)

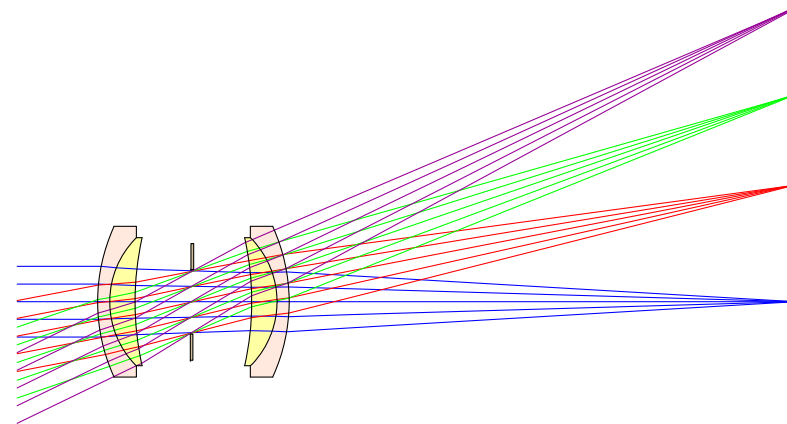

Photographic Lenses

Further Anastigmatic Doublets

- Protar (1890, Rudolph)
 - using new glasses with higher index
- Dagor (1892, Höegh)
 - cemented triplets
 - problem: high zonal spherical aberration

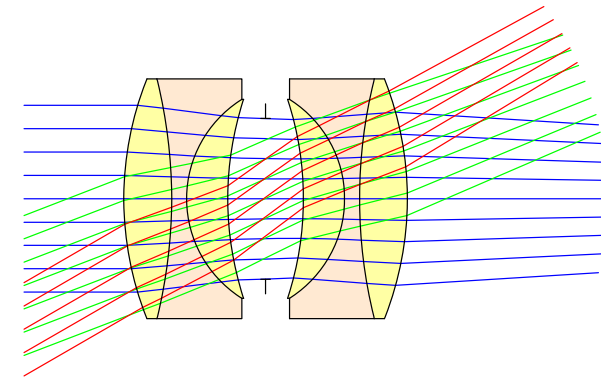
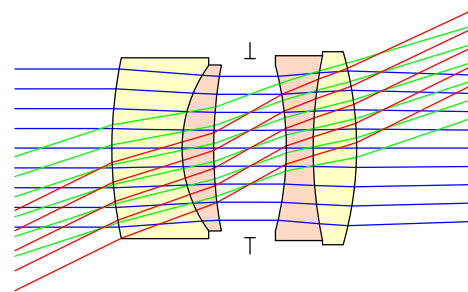

- Orthostigmat (1893, Steinheil)

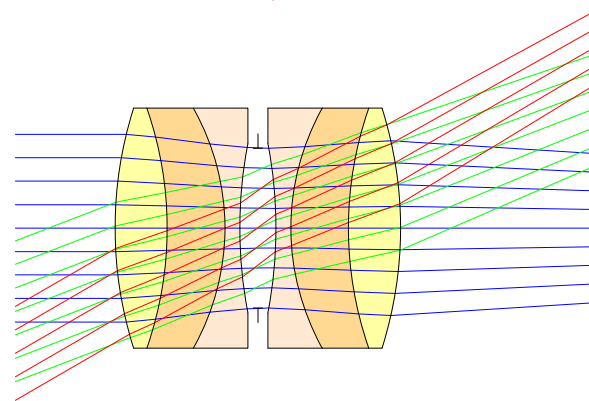

Photographic Lenses

Cooke Triplet

- Cooke Triplet (1893, Taylor)

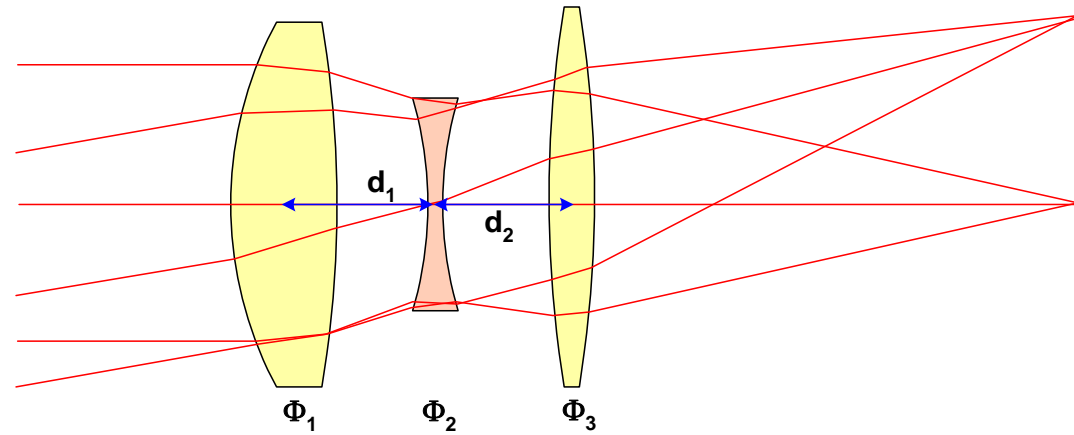

- Analytical solution possible :
8 degrees of freedom (6 radii, 2 air spaces)
→ control seven basic aberrations + focal length

Important : Glass choice
Typical solution areas

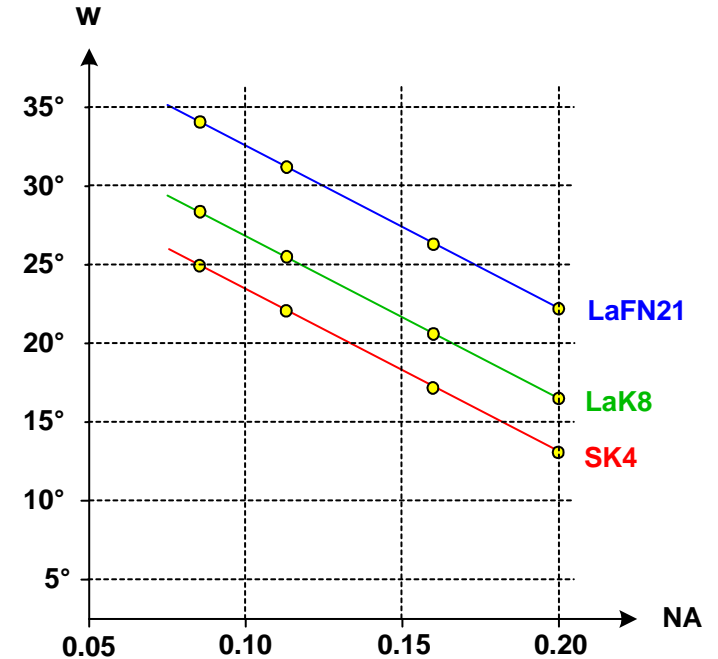

Photographic Lenses

Cooke Triplet

- Example design

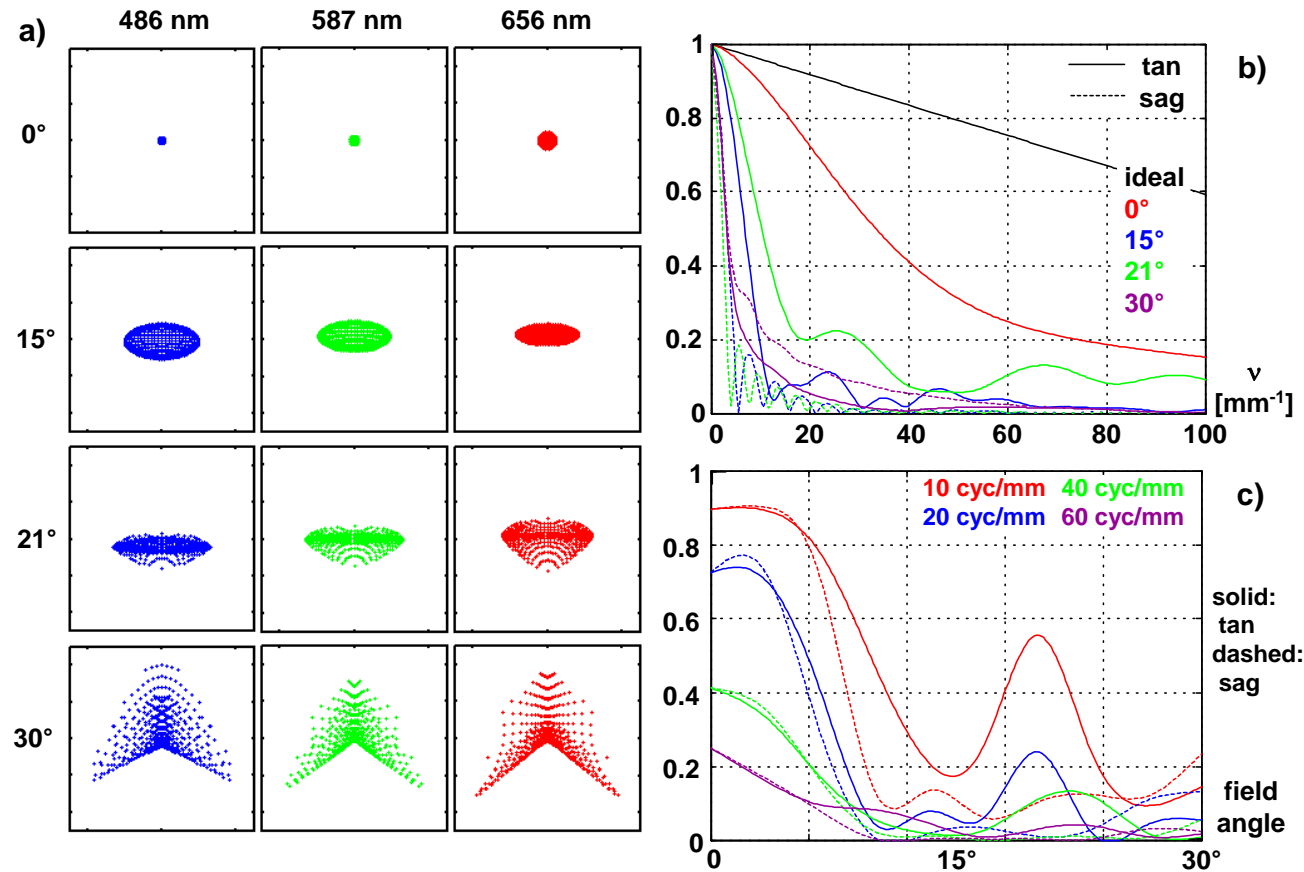
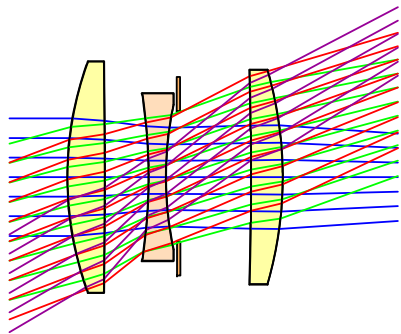

Photographic Lenses

Lens Examples

- Tessar (1902, Rudolph)
 - better corrected higher order aberrations

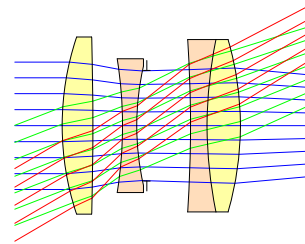

- Heliar (1900 Voigtländer)
 - correction very similar to Tessar

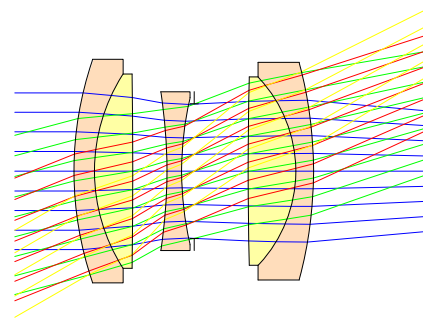

- Pentac (1903 Voigtländer)
 - correction very similar to Tessar

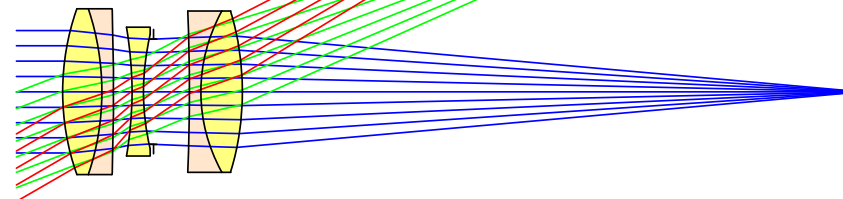

Photographic Lenses

Quasi-Symmetric Wide-Field Lenses

- Double Gauss

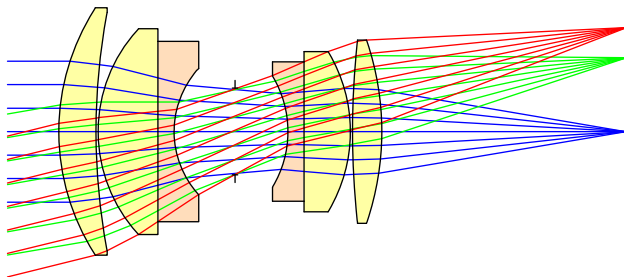
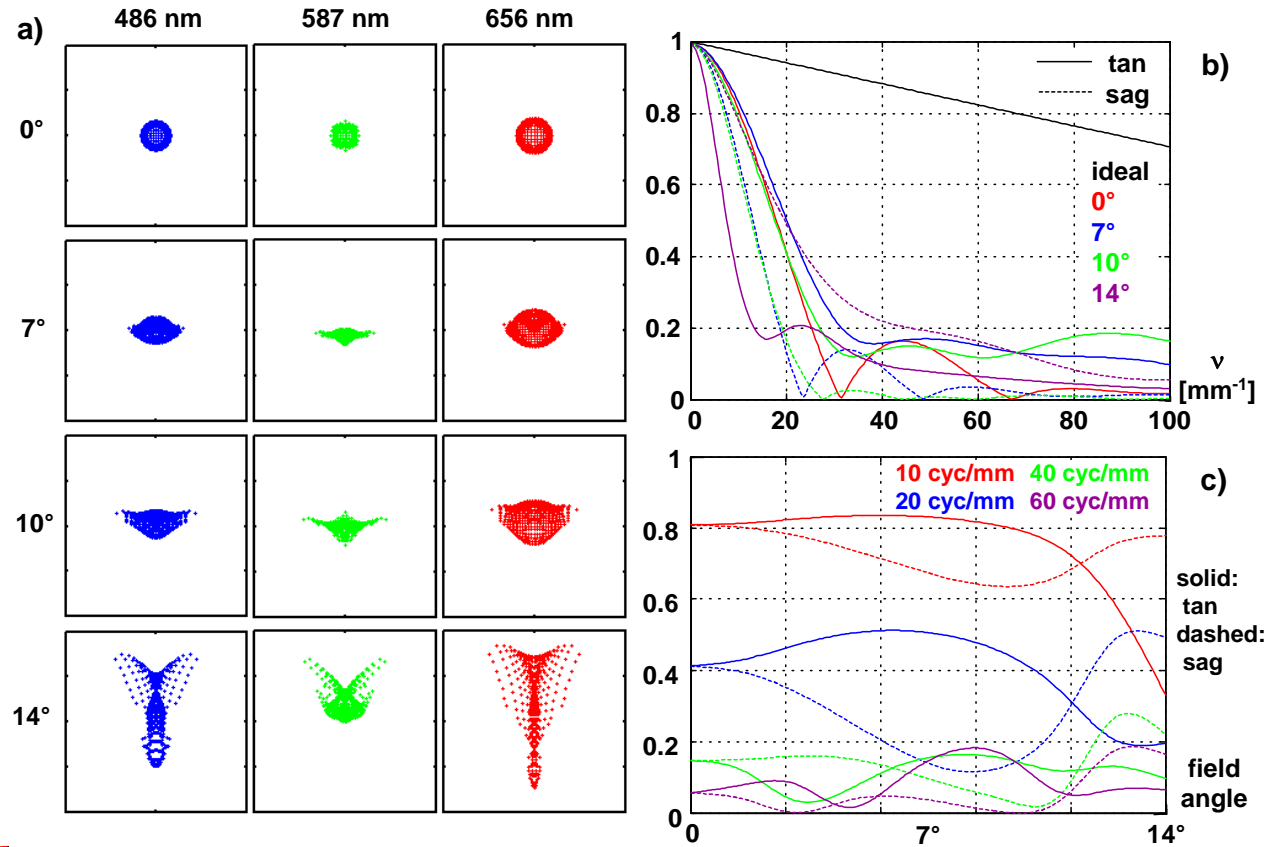

Photographic Lenses

Quasi-Symmetric Wide-Field Lenses

- Double-Gauss variant 30°

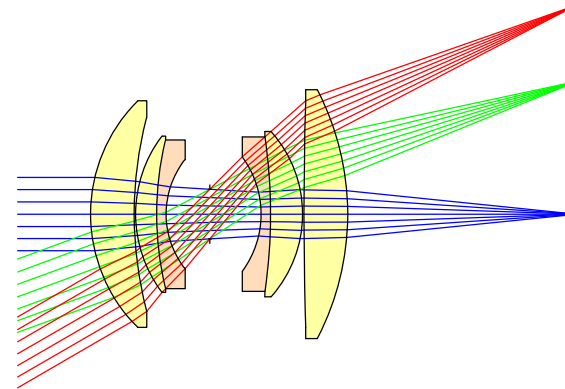

- Large Aperture Double Gauss
f/1.4

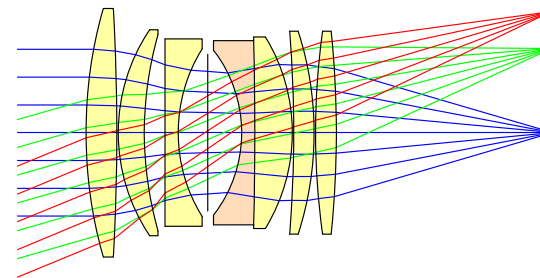

- Planar

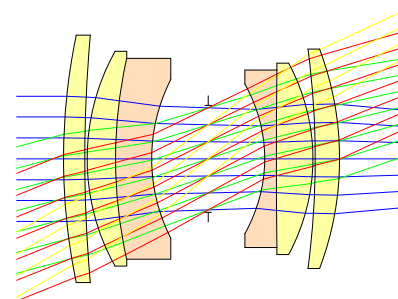

Photographic Lenses

Wide-Angle Lenses

- Hypergon
Strong vignetting

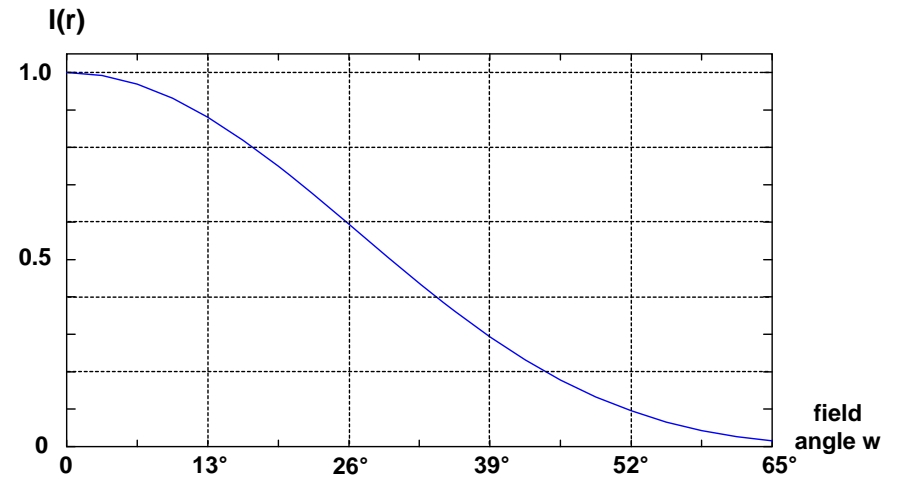
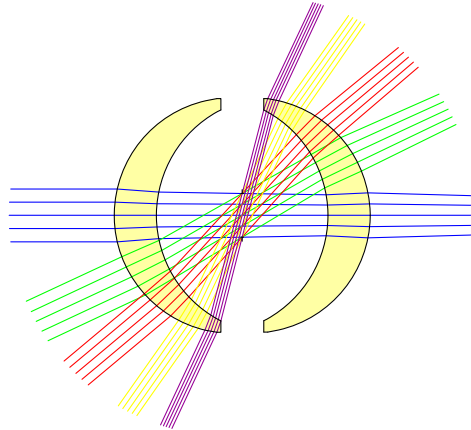

- Topogon
Metrogon

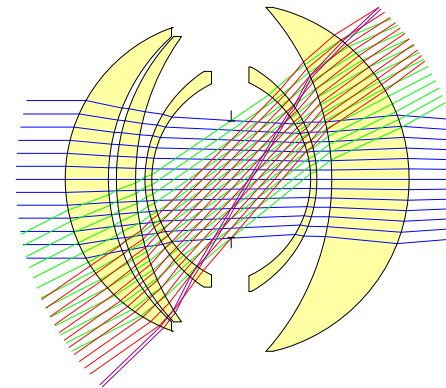
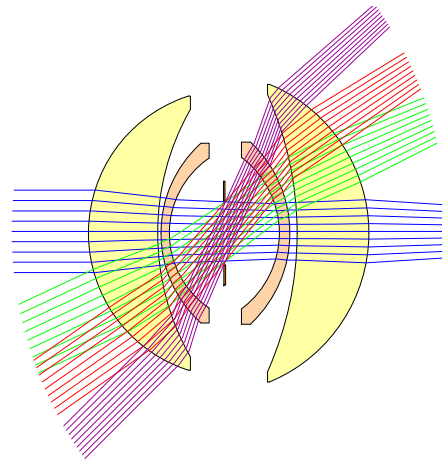

Photographic Lenses

Wide-Angle Lenses

- Hologon
Inverse Triplet

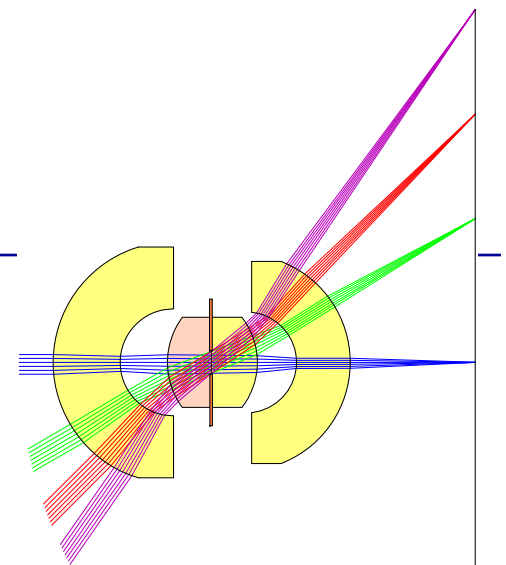

- Pleogon

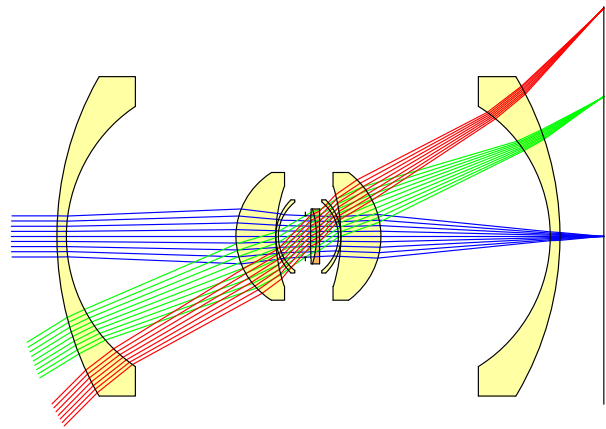

- Biogon

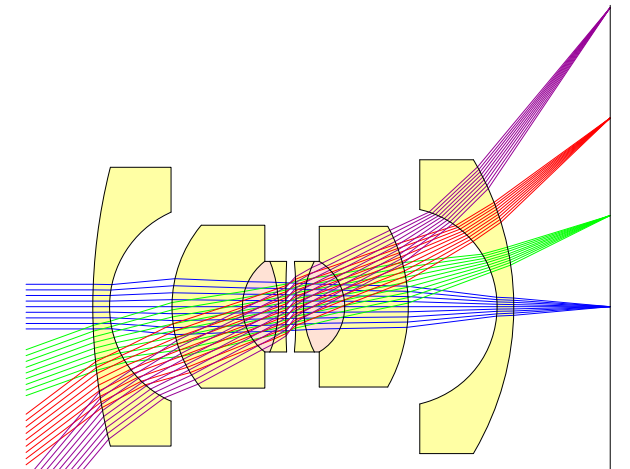

- Super-Angulon

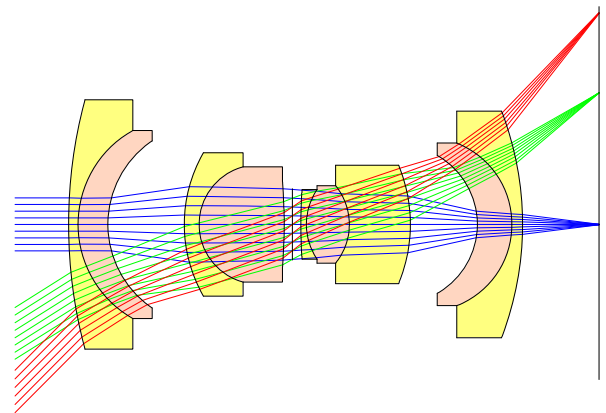

Photographic Lenses

Telephoto Lenses

- Telephoto Principle:
Short system / large focal length

- Reduction factor

$$k = \frac{L}{f'}$$

Range : 0.5 ...0.8

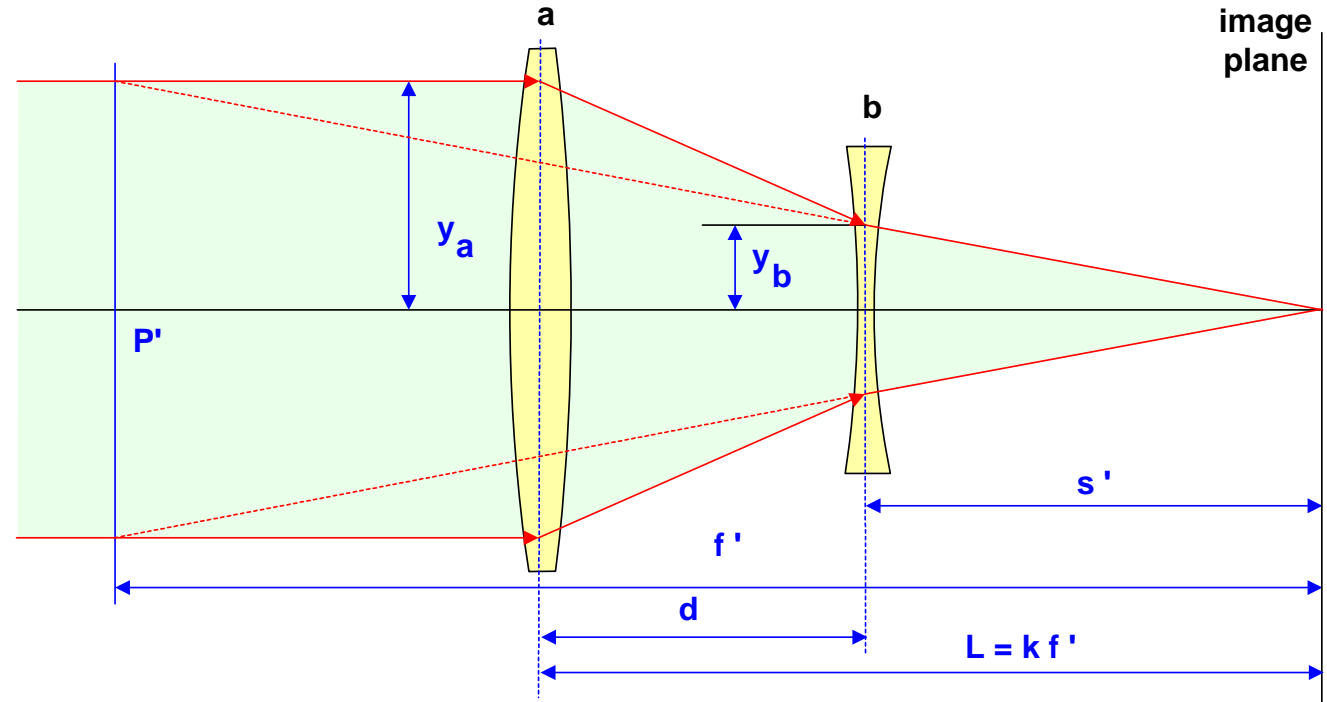

- Layout

$$f_a = \frac{f' \cdot d}{f' \cdot (1 - k) + d} \quad f_b = \frac{(f_a - d)(kf' - d)}{f_a - kf'} \quad d_{opt} = L / 2 = k / 2 \cdot f'$$

Photographic Lenses

Telephoto Lenses

- Example Lenses

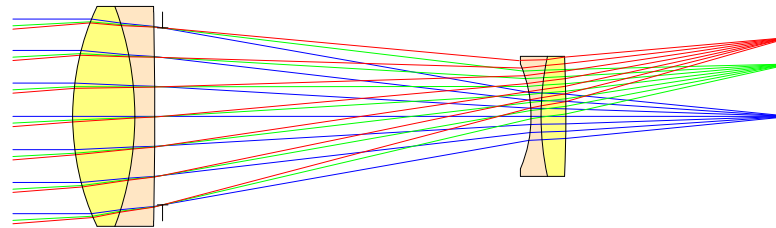

- Floating element

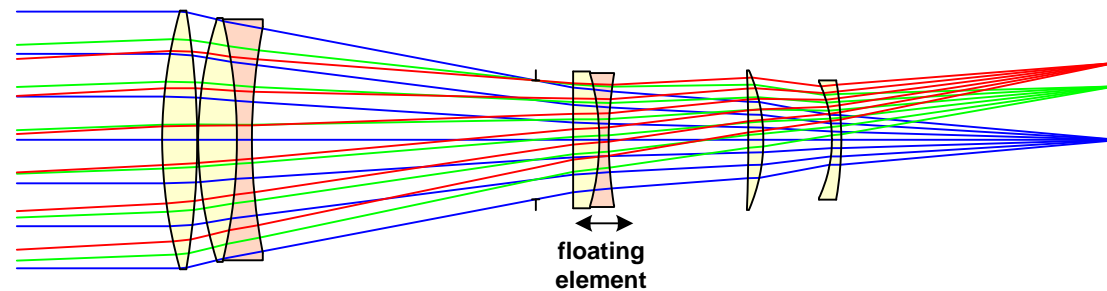
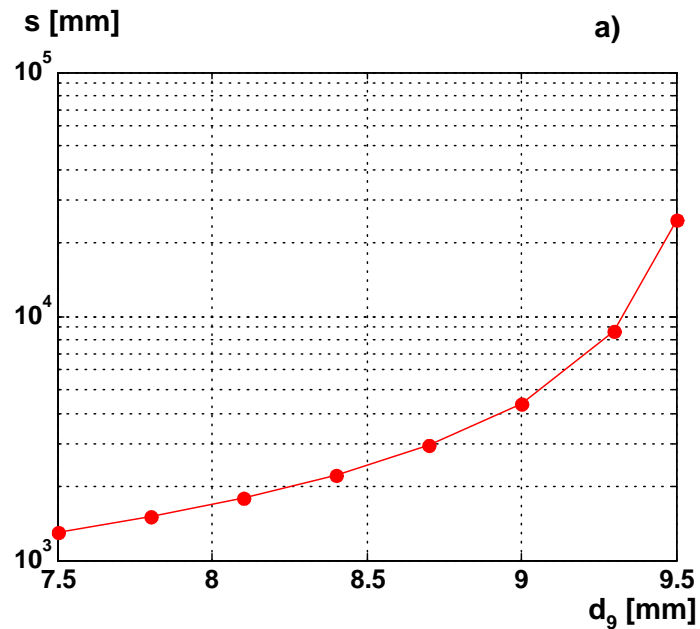
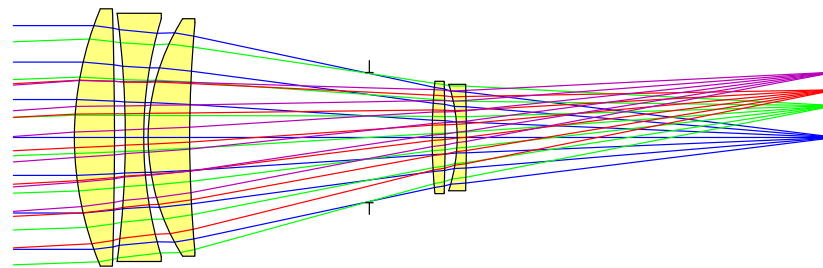

Photographic Lenses

Retrofocus Lenses

- Retrofocus Principle
Large working distance /
short focal length

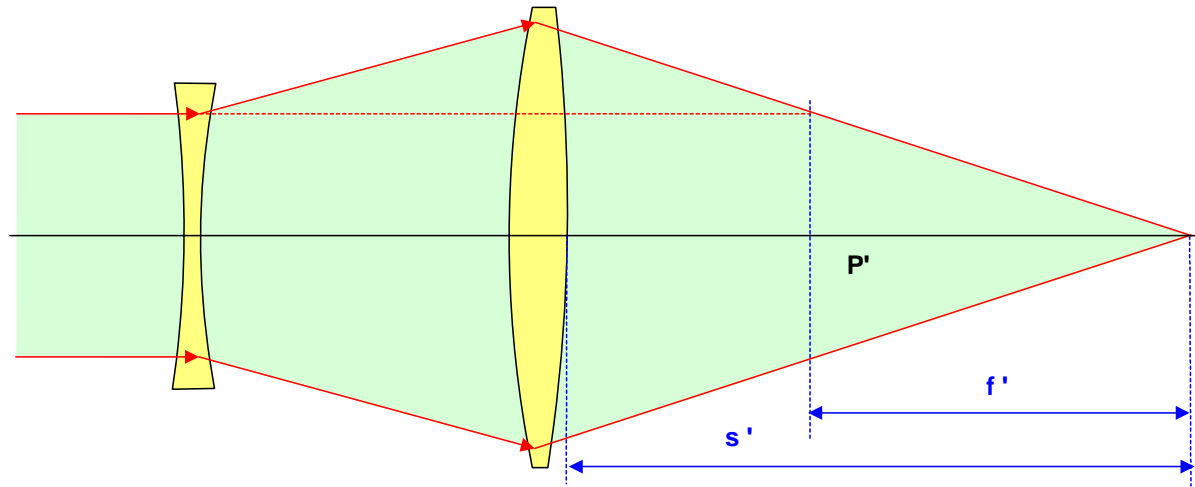

- Inverse Telephoto Lens

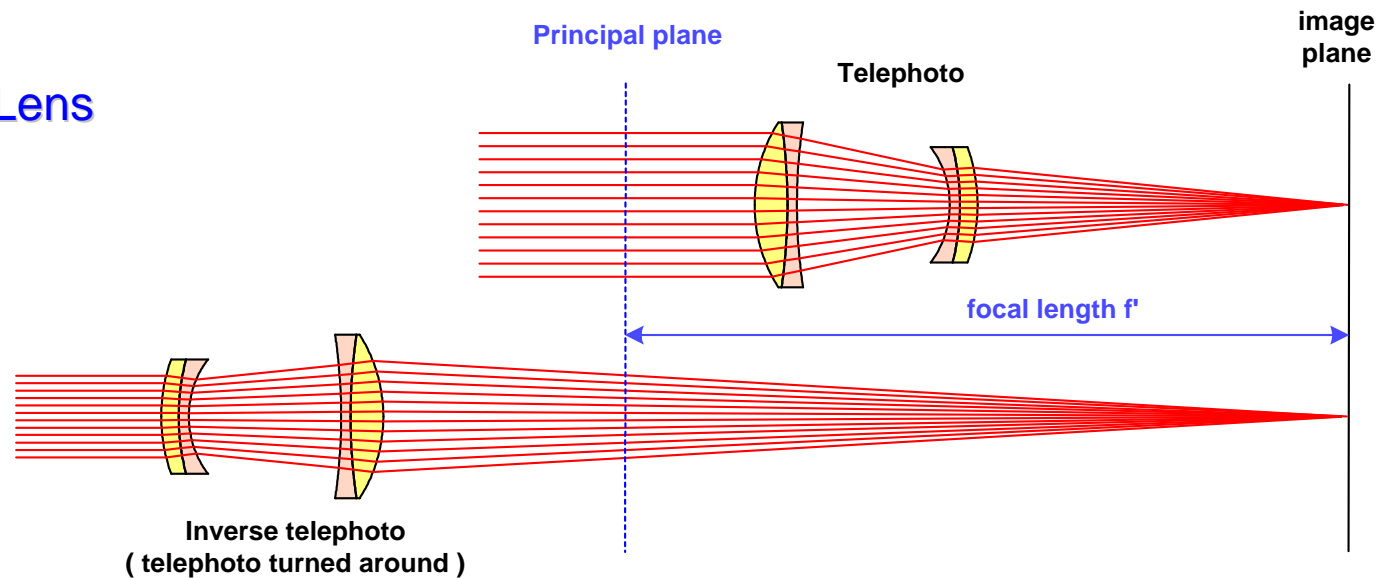

Photographic Lenses

Retrofocus Lenses

Example lens

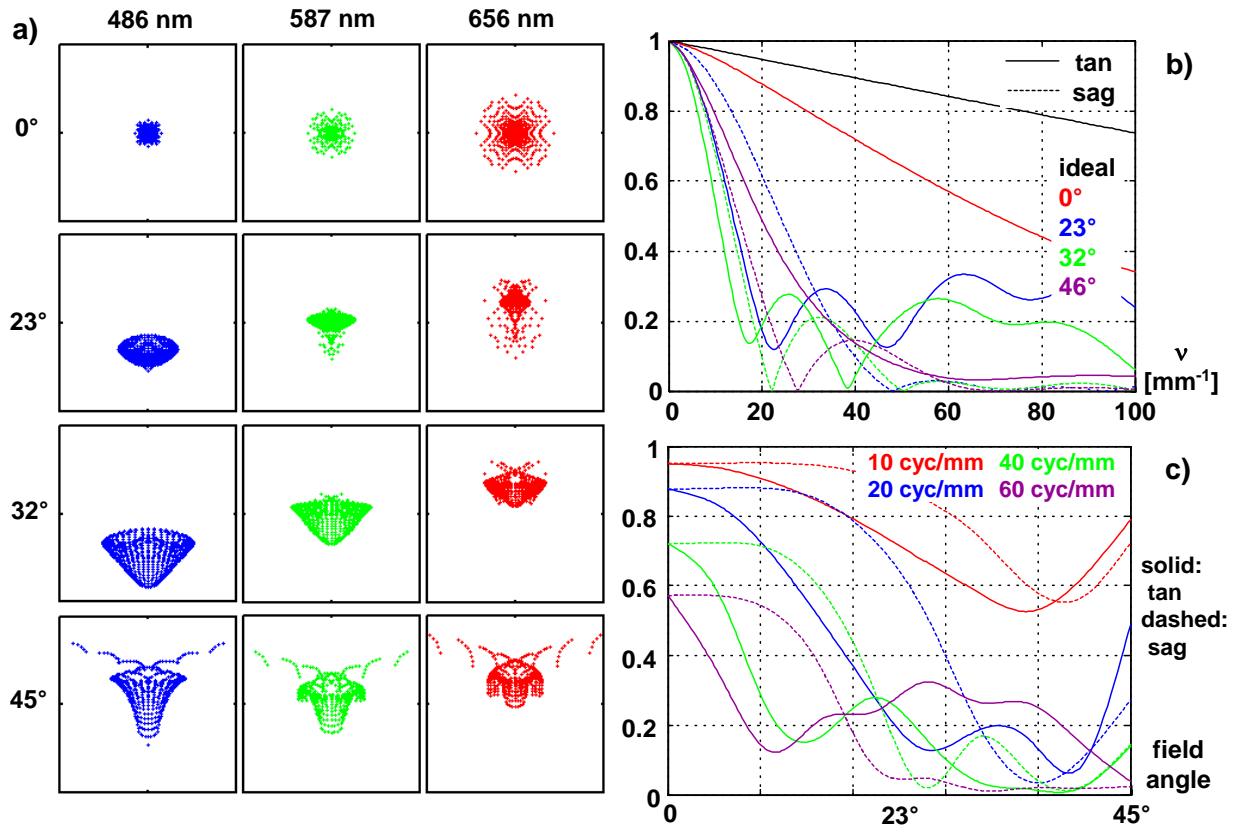
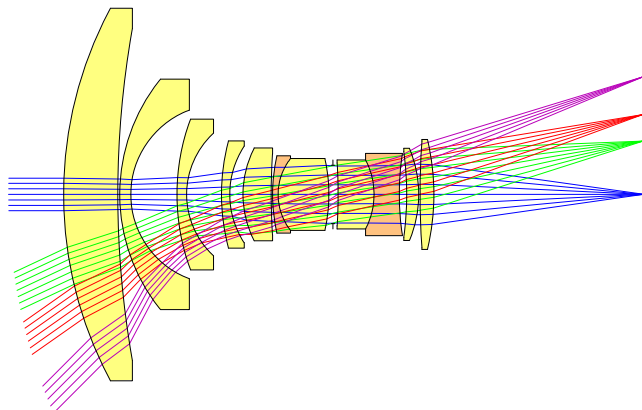
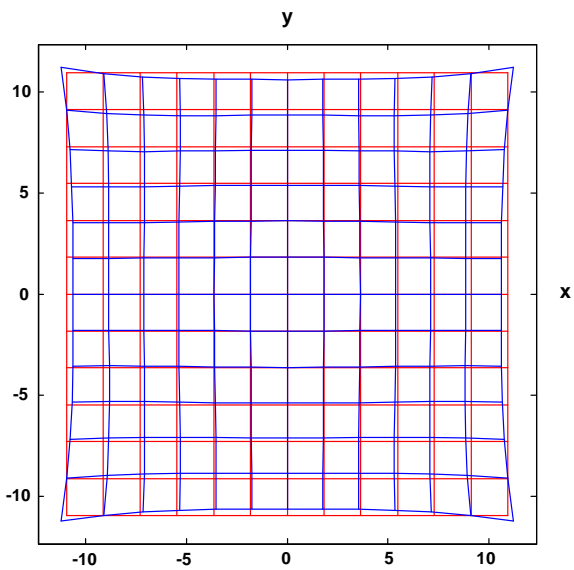

Photographic Lenses

Retrofocus Lenses

- Example lens 2

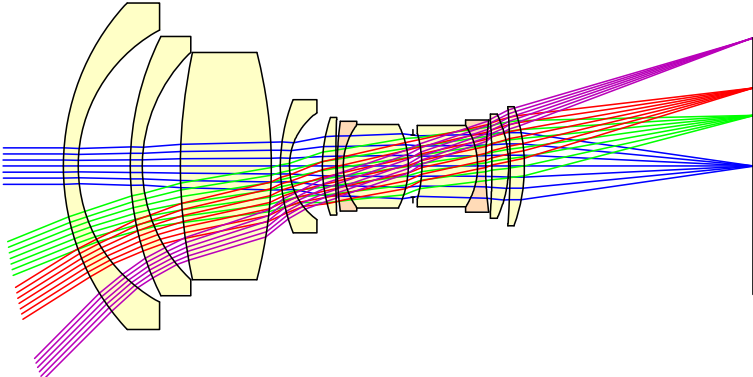

- Distagon

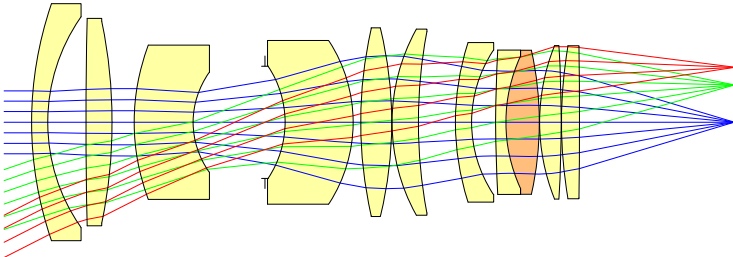
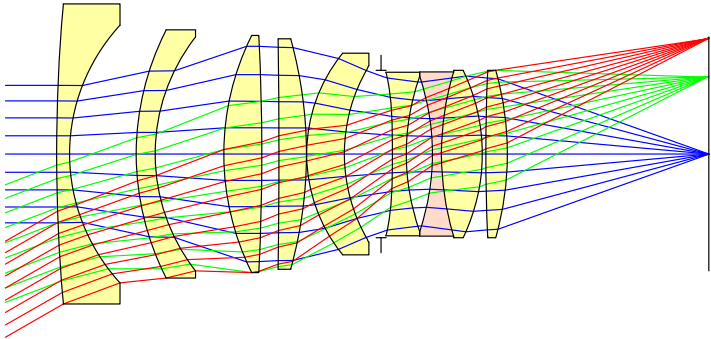

Photographic Lenses

Fish-Eye-Lens

▪ Example lens

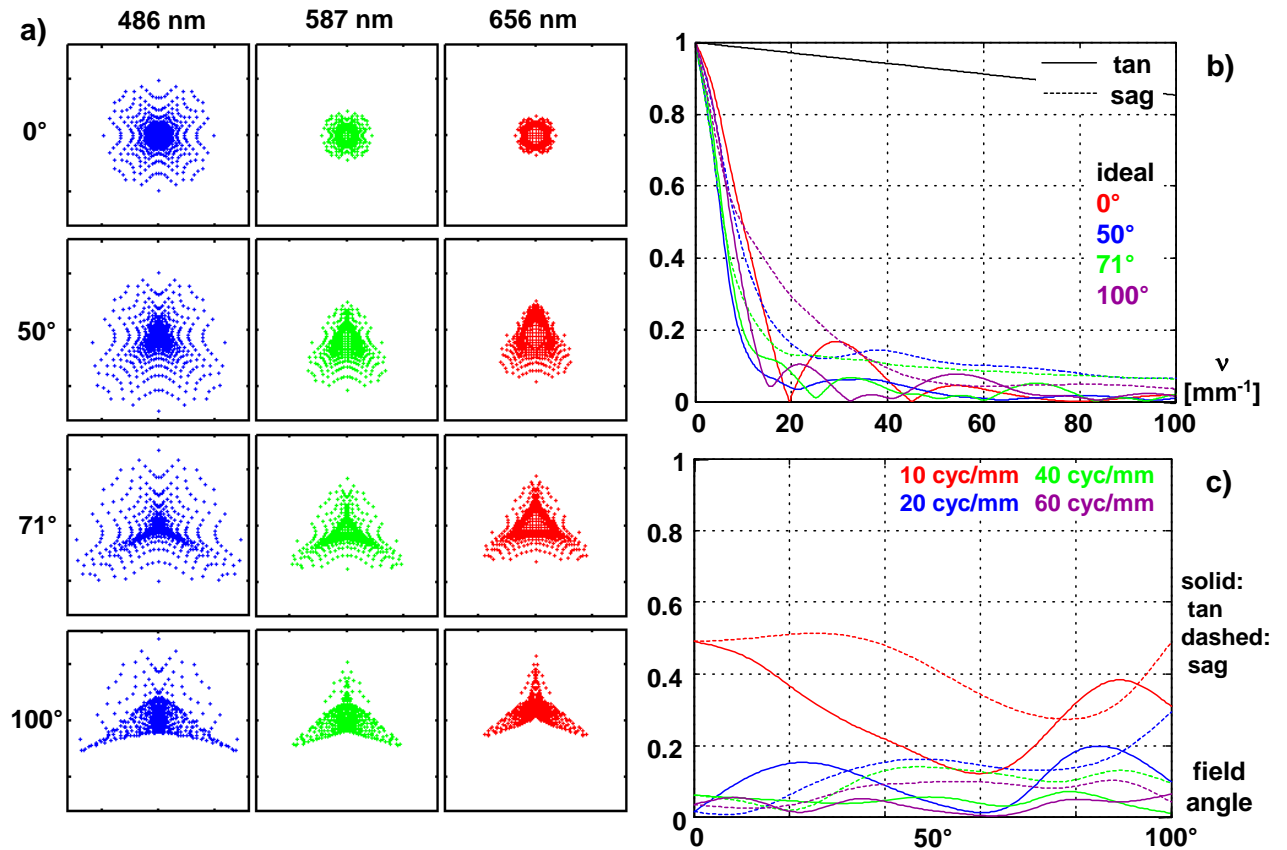
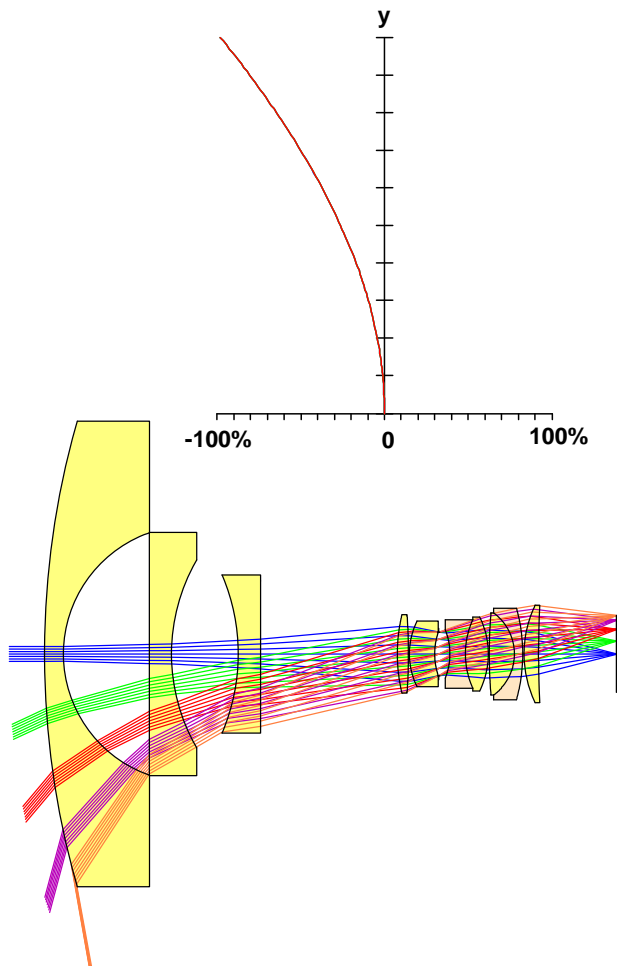

Photographic Lenses

Fish-Eye-Lens

- Nikon 210°

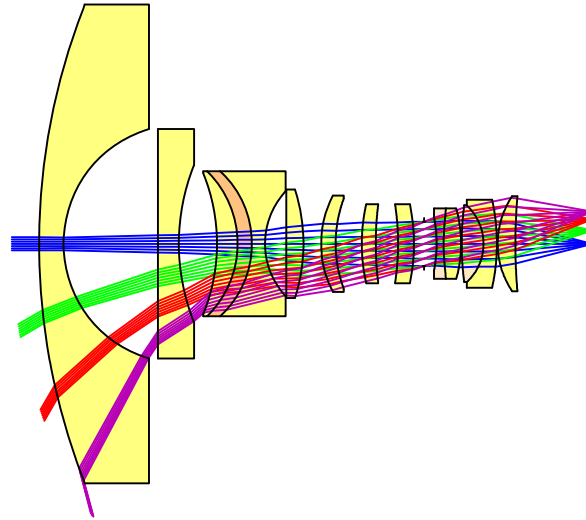

- Pleon

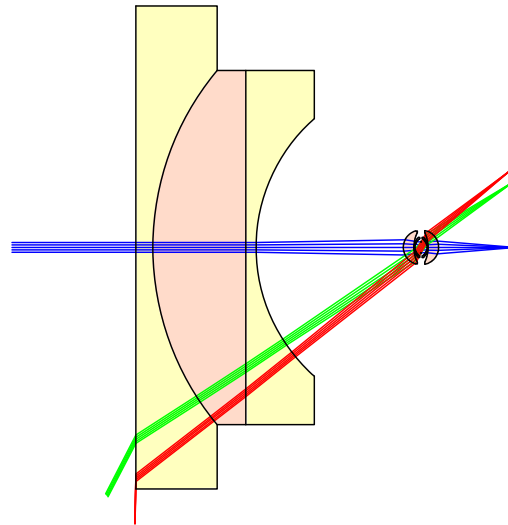

Photographic Lenses

Fish-Eye-Lens

- Pupil variation:
position and orientation

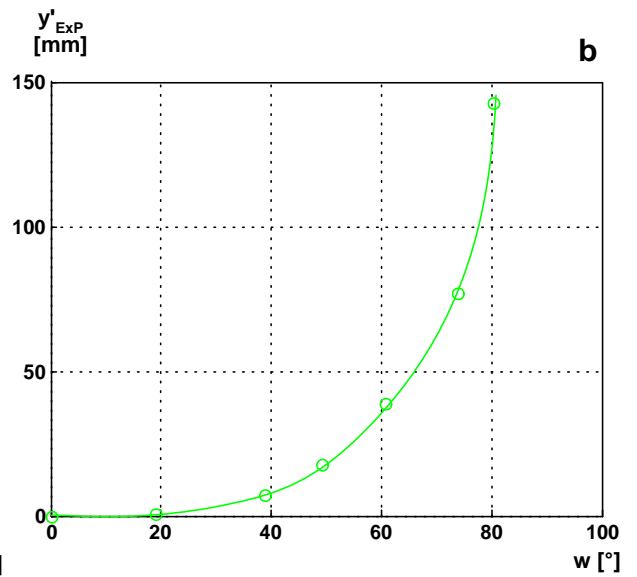
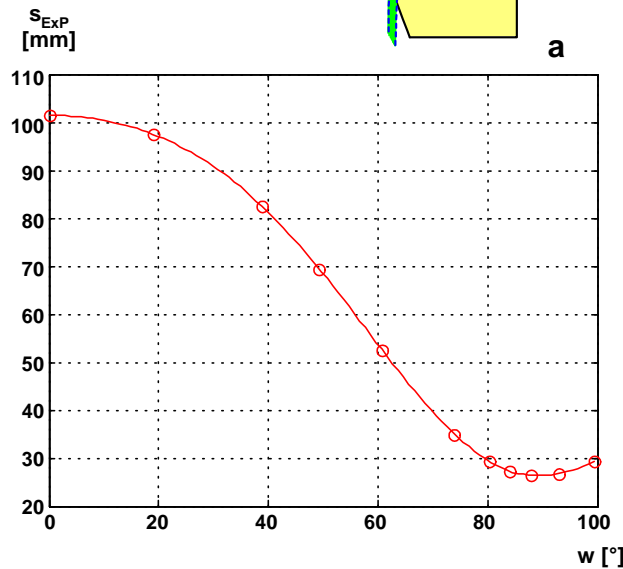
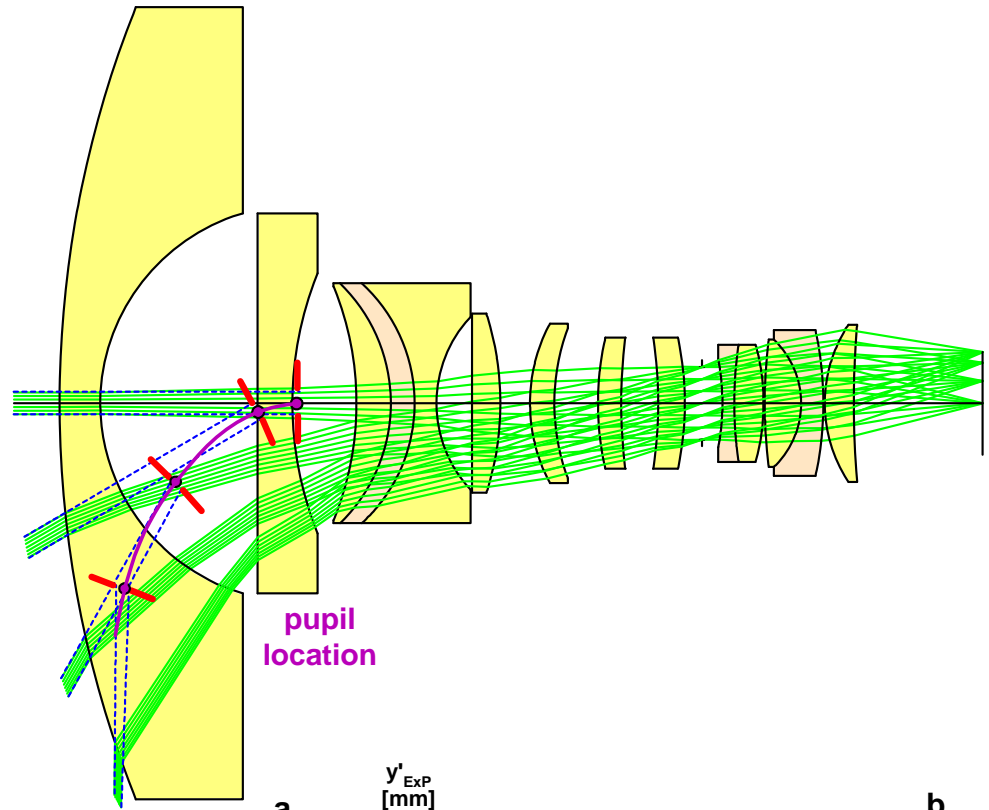

Photographic Lenses

Fish-Eye-Lens

- Pupil variation:
Shape

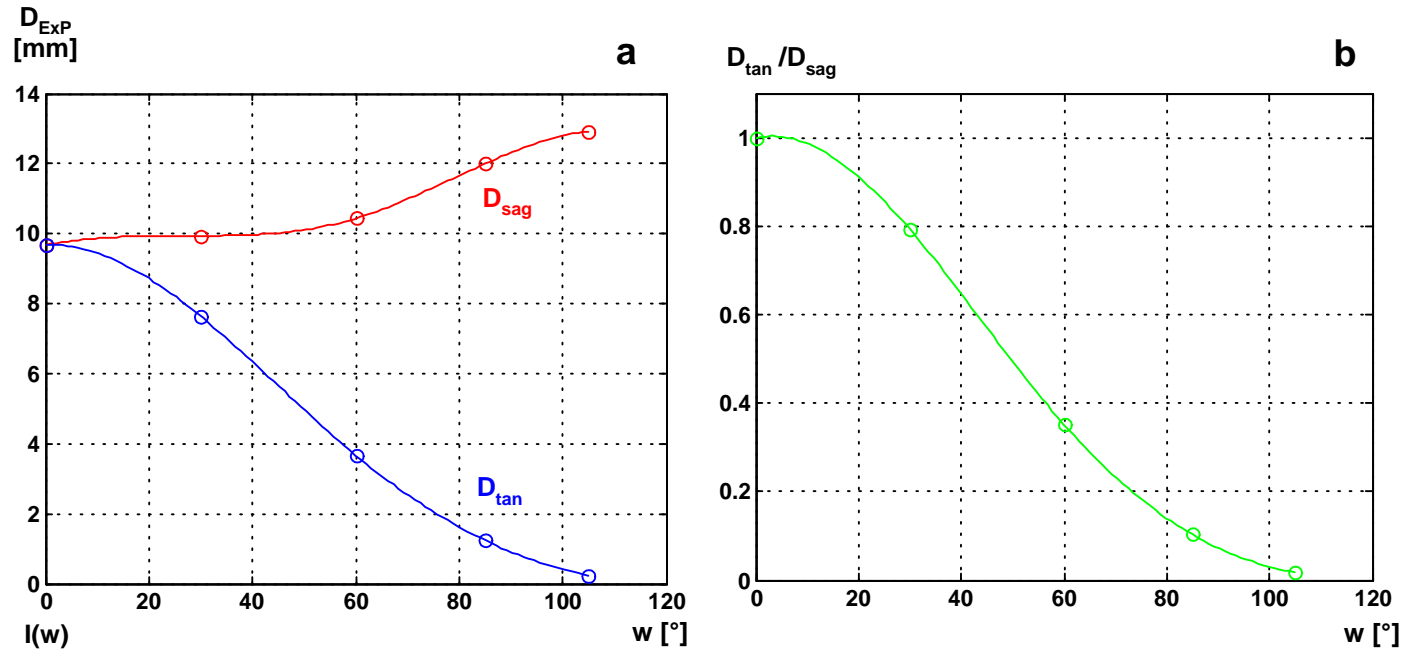

- Brightness

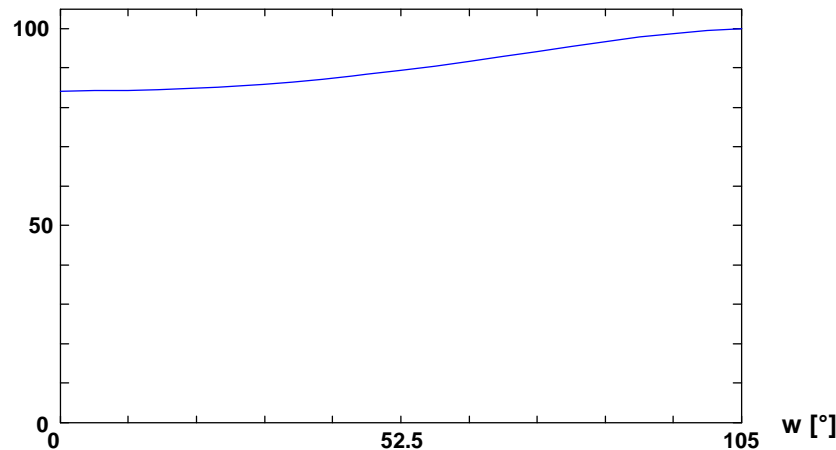

Photographic Lenses

Special Designs

- Catadioptric Lenses

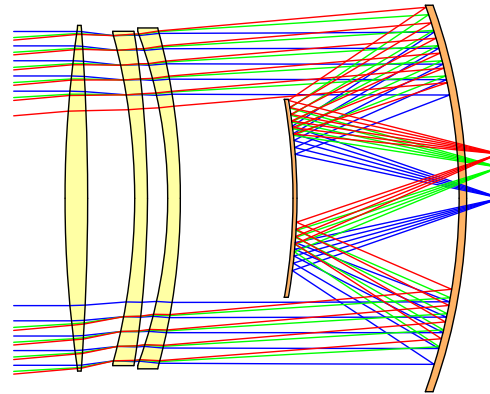

- Relatively small field angle

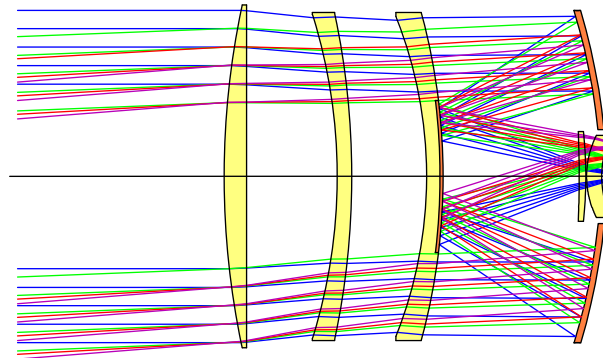

Photographic Lenses

Special Designs

- Compact Camera

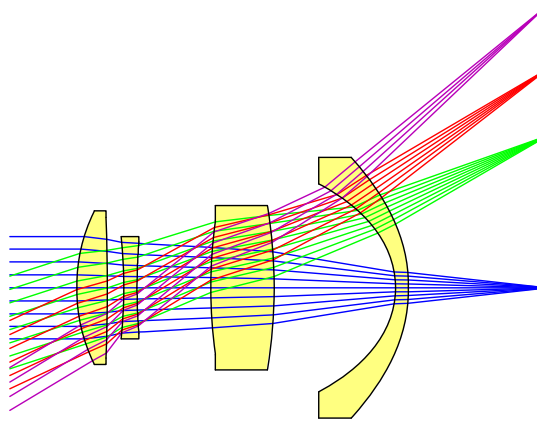

- Plastic Aspheric Lens

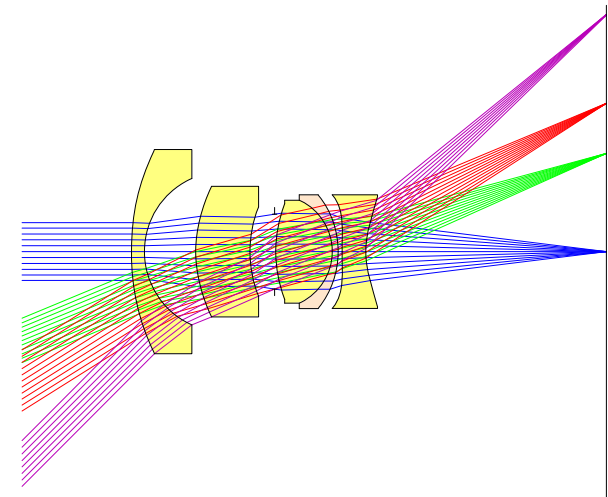

- Mobile Phone camera

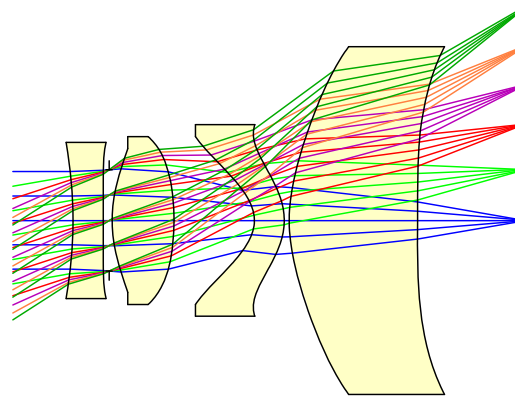

Photographic Lenses

Special Designs

- UV-Lens

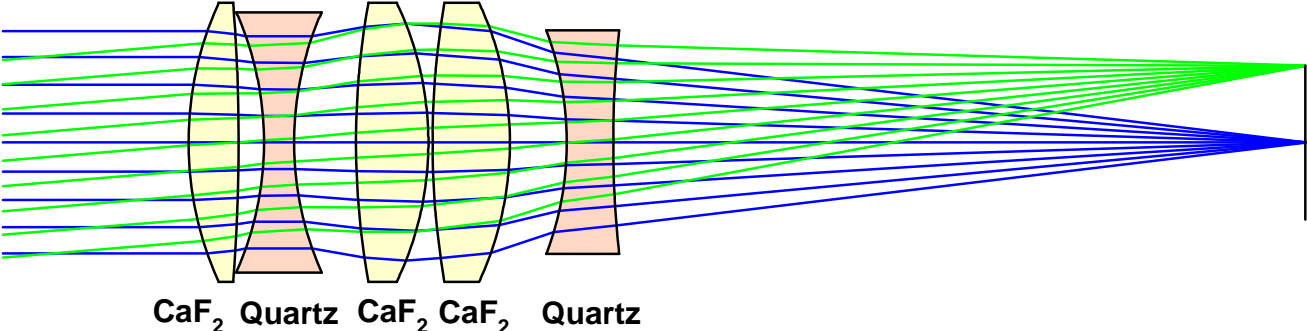

- IR-Lens

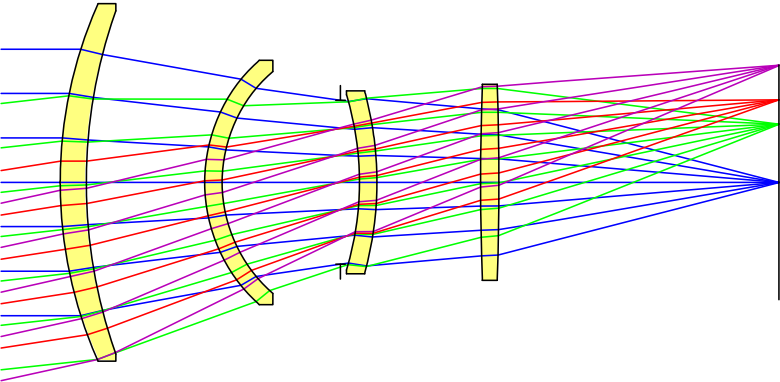

Photographic Lenses

Vignetting

- Reduction of field aberrations

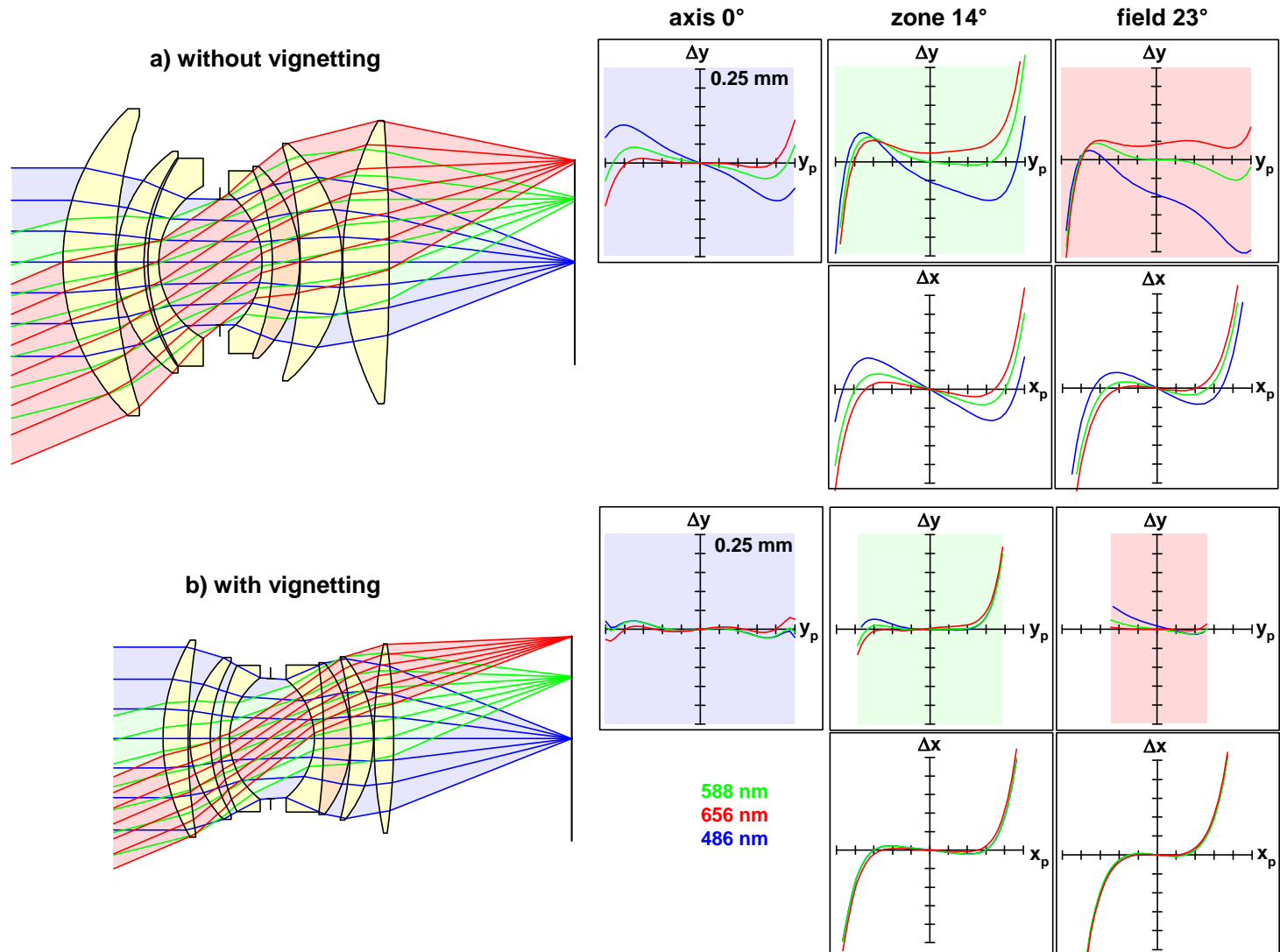

Photographic Lenses

Stopping Down

- Resolution:
Geometric versus diffraction
- Example Double Gauss

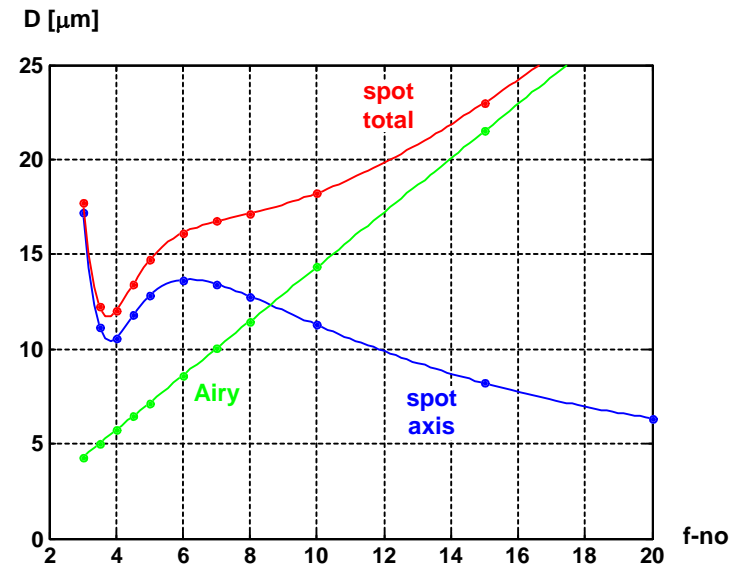
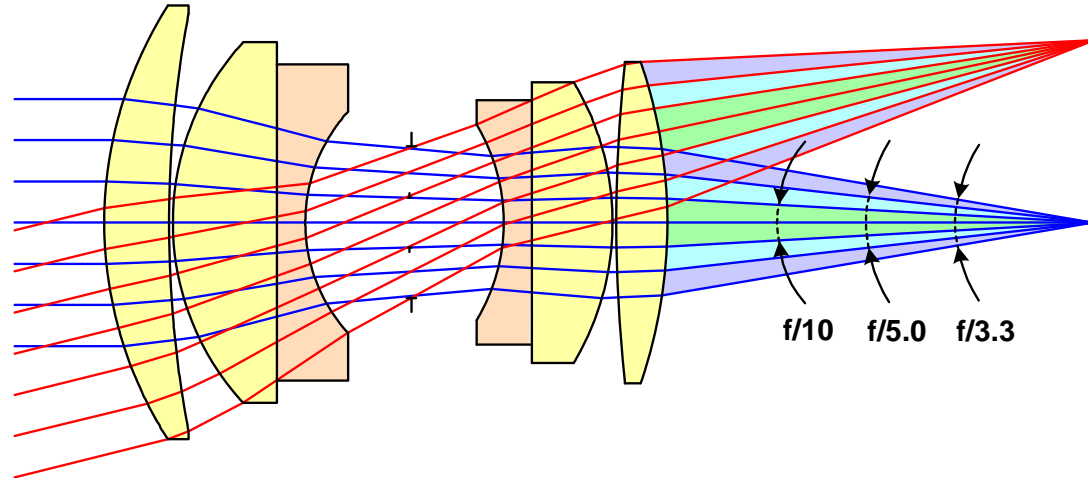

Photographic Lenses

Stopping Down

- Example Triplet

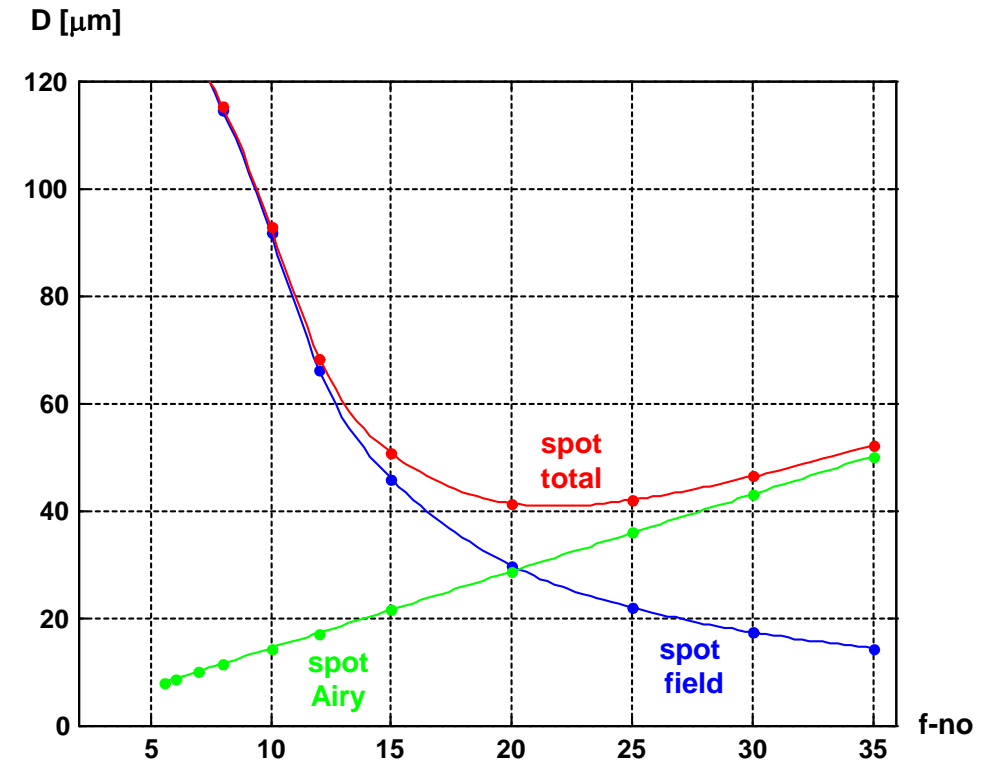
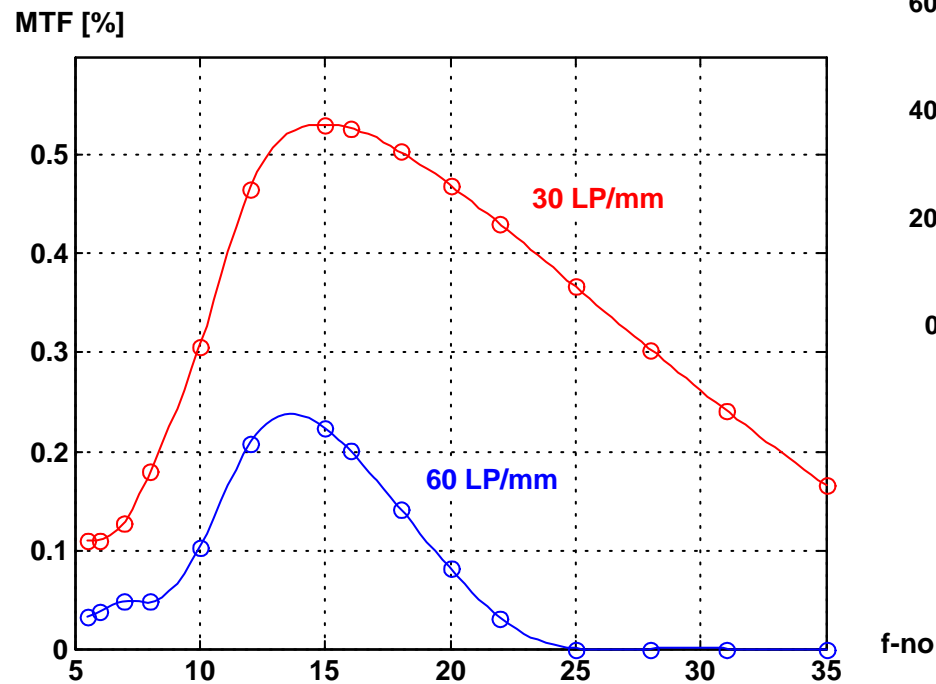

Photographic Lenses

Stopping Down

- Resolution versus depth of field

a) f/28



b) f/56



c) f/80



Photographic Lenses

Floating Elements

- Refocussing near distances
- Performance improvement
- Combined with lens movement

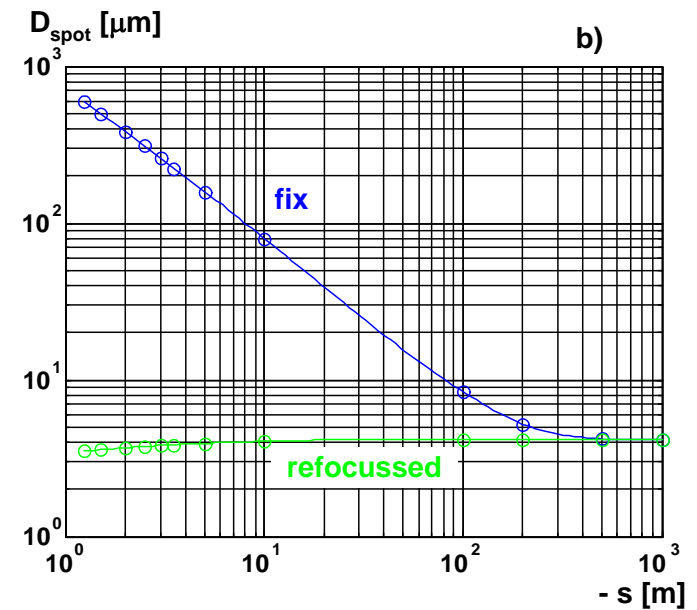
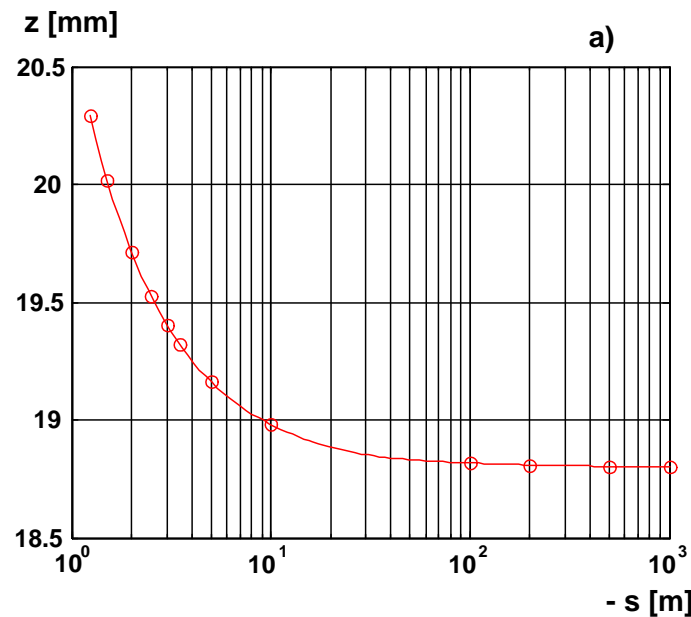
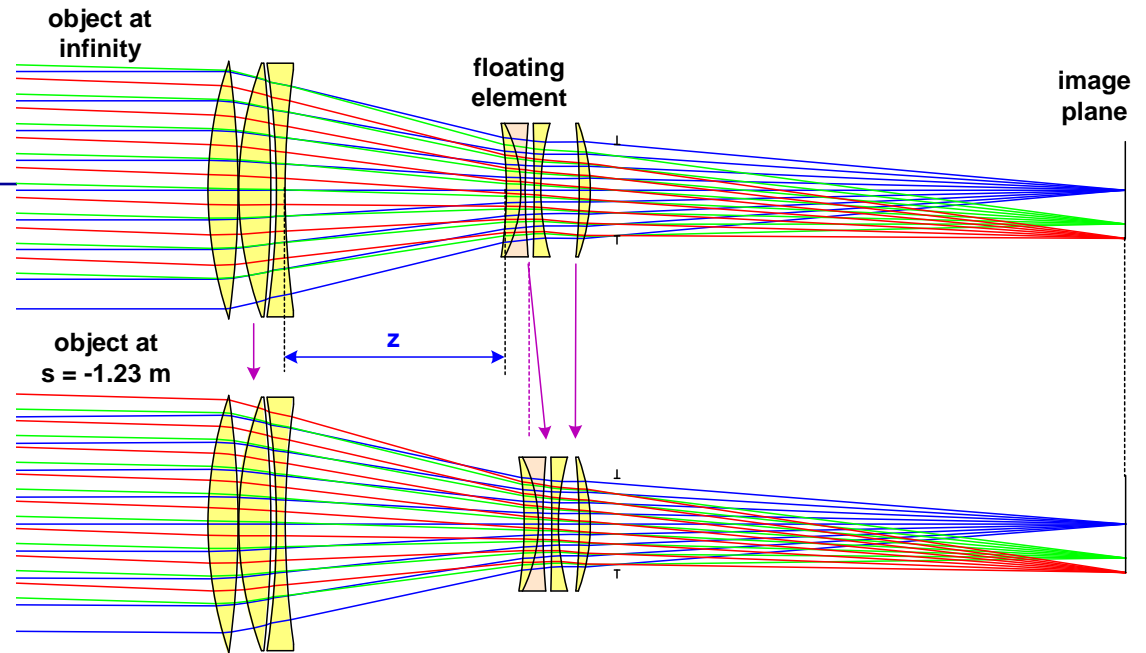

Photographic Lenses

Modularität moderner Filmkamaras

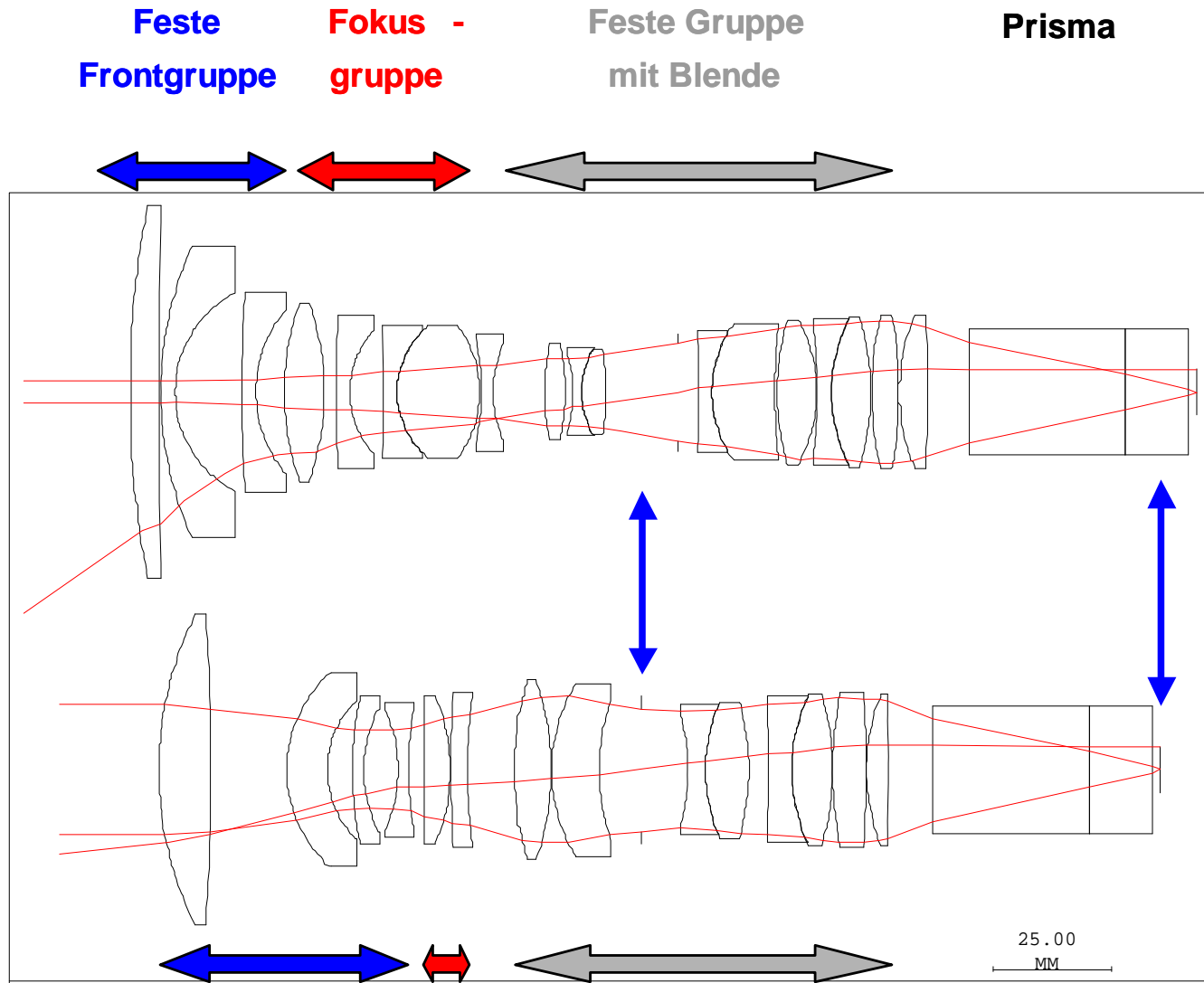

Photographic Lenses

Straylight and Ghost Images

- Different reasons
- Various distributions

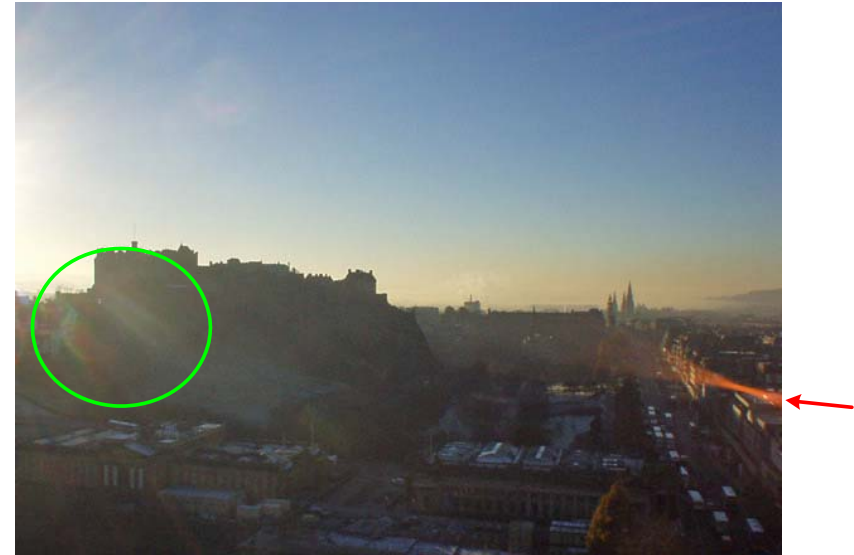

Photographic Lenses

Straylight and Ghost Images

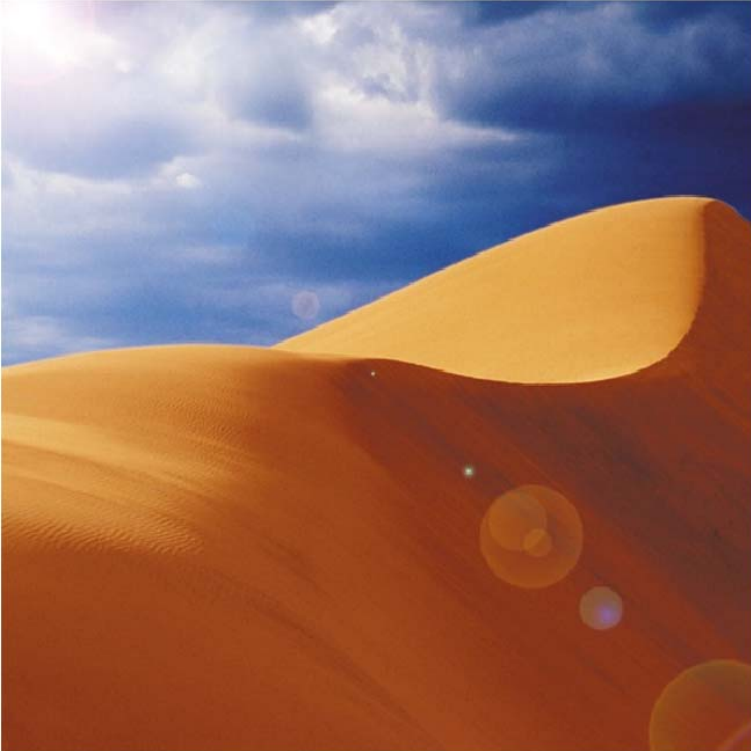

Photographic Lenses

Straylight and Ghost Images

- Calculation of reflected light

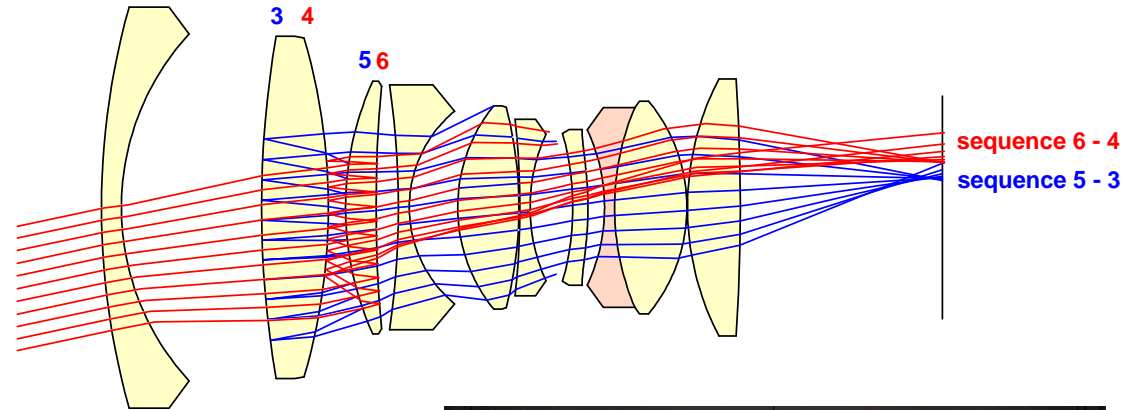

- Colour effects due to coatings

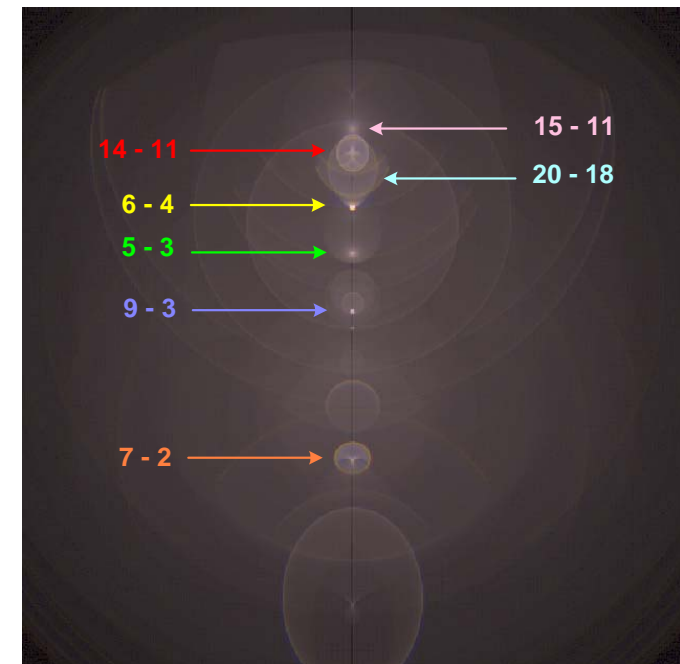
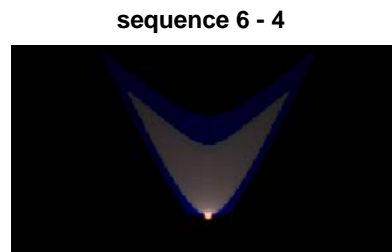
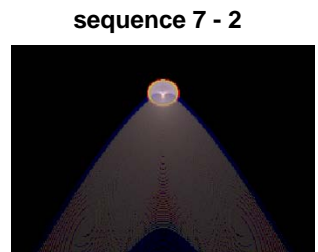
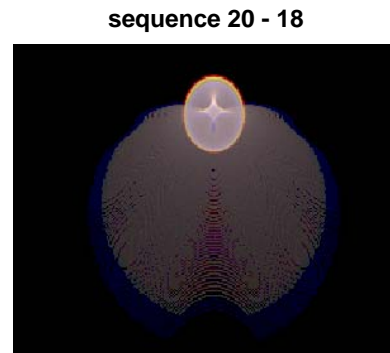
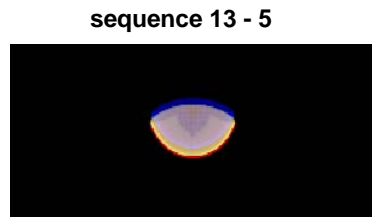
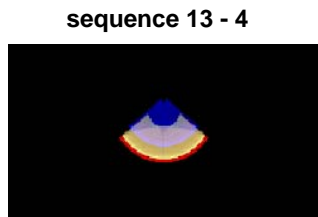

Photographic Lenses
