

Elgersburg Lectures – March 2010

Lecture III

LATENT VARIABLES

Theme

First-principles models invariably contain latent (auxiliary) variables in addition to the (manifest) variables the model aims at.

In this lecture we study the emergence of latent variables and their elimination for LTIDSs.

Outline

- ▶ **The emergence of latent variables in physical models**
- ▶ **The elimination theorem**
- ▶ **The three theorems**
- ▶ **State models**
- ▶ **State construction for discrete-time LTIDSs**
- ▶ **State construction for continuous-time LTIDSs**

Springs in series and in parallel

Interconnected springs

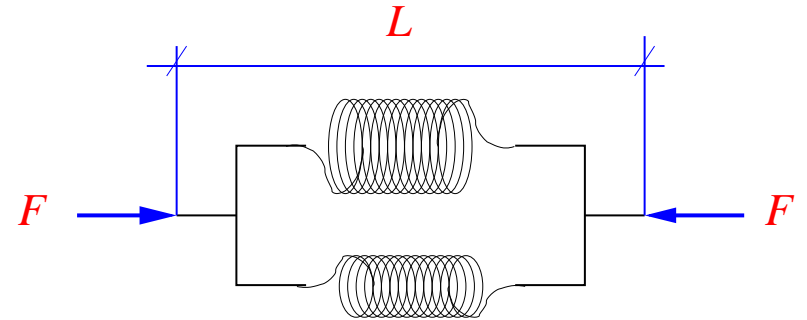
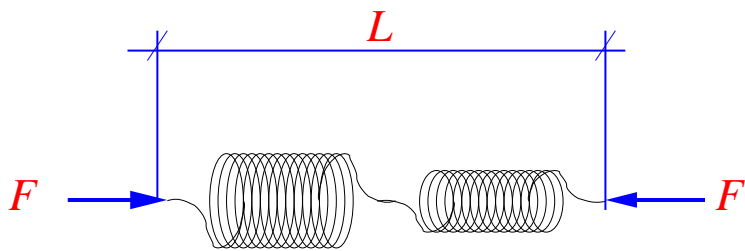

!! Model the relation between L and F !!

Interconnected springs

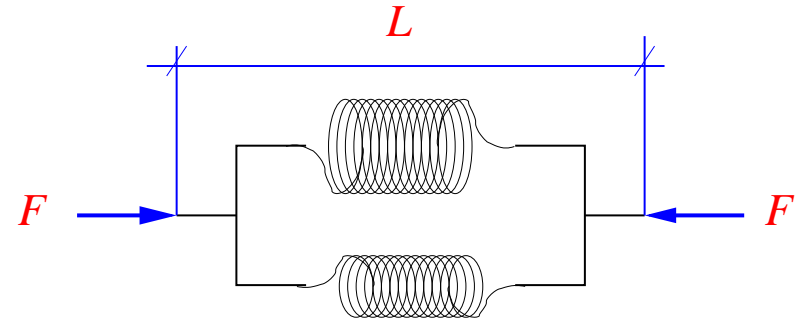
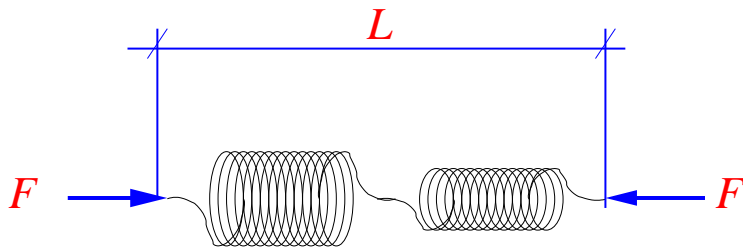

!! Model the relation between L and F !!

Typical force/length characteristic for a simple spring.

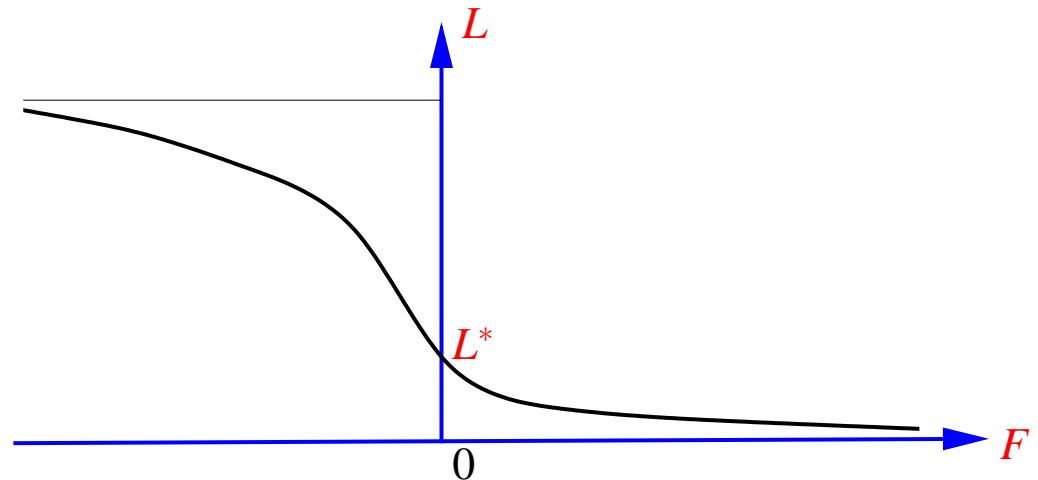
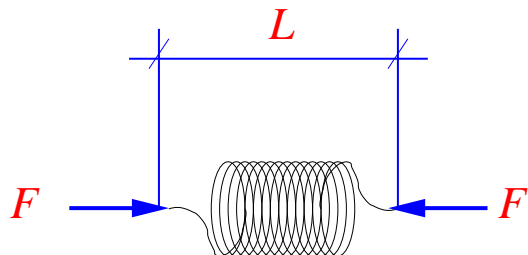

Springs in series

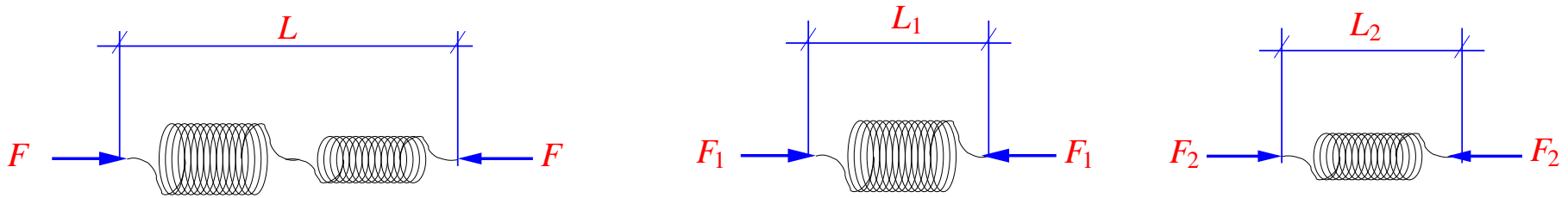

Model for (L, F) (assume that for the individual springs the length is a function of the force):

$$\begin{aligned}L_1 &= \rho_1(F_1), & L_2 &= \rho_2(F_2), \\ F &= F_1 = F_2, & L &= L_1 + L_2.\end{aligned}$$

(L, F) : **‘manifest’**, (L_1, F_1, L_2, F_2) : **‘latent’** variables.

Springs in series

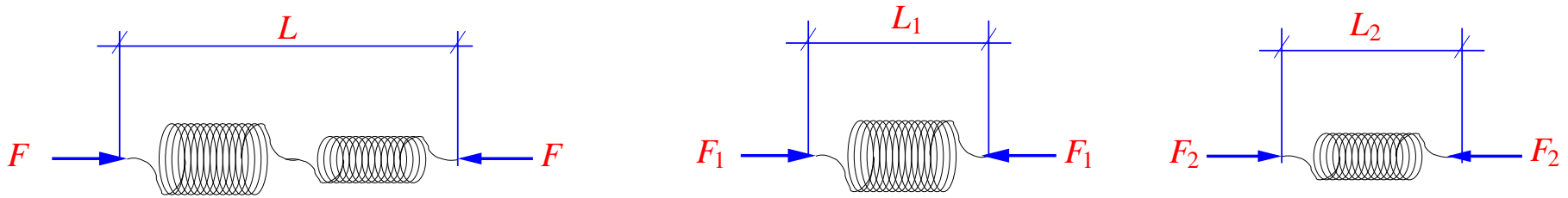

Model for (L, F) (assume that for the individual springs the length is a function of the force):

$$\begin{aligned}L_1 &= \rho_1(F_1), & L_2 &= \rho_2(F_2), \\ F &= F_1 = F_2, & L &= L_1 + L_2.\end{aligned}$$

(L, F) : ‘manifest’, (L_1, F_1, L_2, F_2) : ‘latent’ variables.

After elimination of the latent variables: $L = \rho_1(F) + \rho_2(F)$.

Latent variables are easily eliminated in this case.

Springs in series

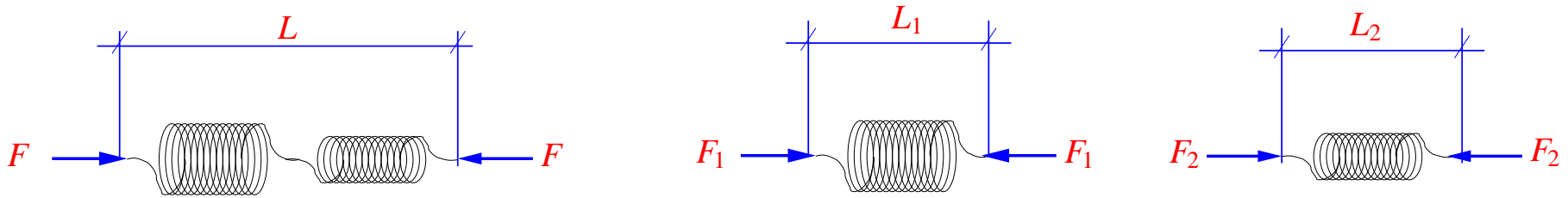

Model for (L, F) (assume that for the individual springs the length is a function of the force):

$$L_1 = \rho_1(F_1), \quad L_2 = \rho_2(F_2),$$

$$F = F_1 = F_2, \quad L = L_1 + L_2.$$

(L, F) : ‘manifest’, (L_1, F_1, L_2, F_2) : ‘latent’ variables.

After elimination of the latent variables: $L = \rho_1(F) + \rho_2(F)$.

Latent variables are easily eliminated in this case.

Linear springs: $L_1 = L_1^* + \rho_1 F_1, L_2 = L_2^* + \rho_2 F_2,$

$$\rightsquigarrow L = L_1^* + L_2^* + (\rho_1 + \rho_2)F.$$

Springs in parallel

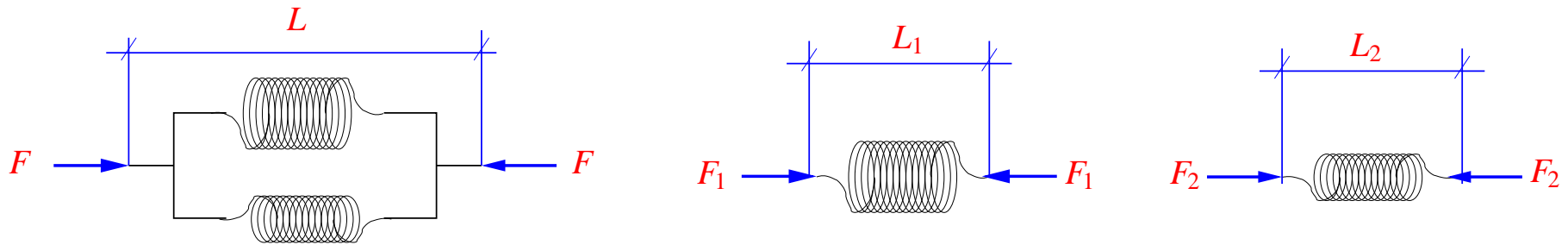

Model for (L, F) (assume that for the individual springs the length is a function of the force):

$$L_1 = \rho(F_1), \quad L_2 = \rho(F_2),$$

$$F = F_1 + F_2, \quad L = L_1 = L_2.$$

(L, F) : **‘manifest’**, (L_1, F_1, L_2, F_2) : **‘latent’** variables.

Springs in parallel

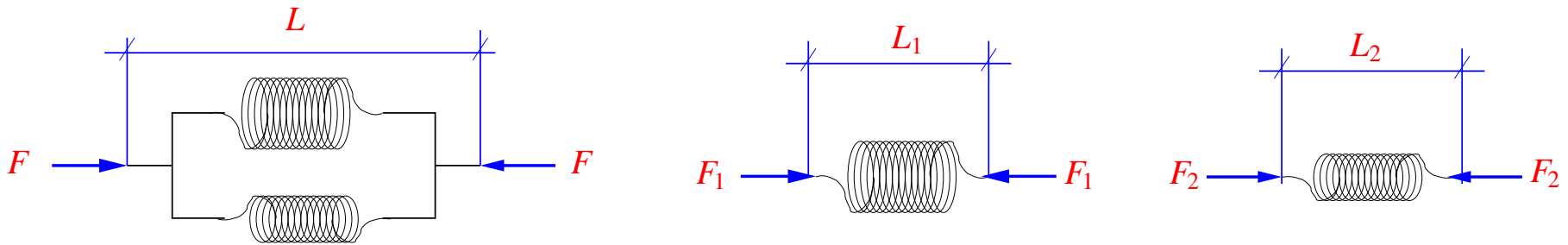

Model for (L, F) (assume that for the individual springs the length is a function of the force):

$$L_1 = \rho(F_1), \quad L_2 = \rho(F_2),$$
$$F = F_1 + F_2, \quad L = L_1 = L_2.$$

(L, F) : **‘manifest’**, (L_1, F_1, L_2, F_2) : **‘latent’** variables.

After elimination of the latent variables:

$$\mathcal{B} = \{(L, F) \mid \exists \alpha : L = \rho_1(\alpha) = \rho_2(F - \alpha)\}.$$

Latent variables are **not easily eliminated in this case.**

Springs in parallel

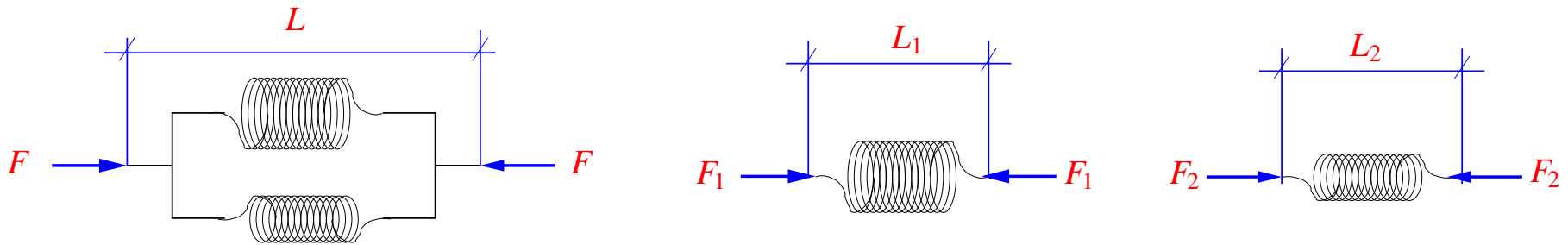

Model for (L, F) (assume that for the individual springs the length is a function of the force):

$$L_1 = \rho(F_1), \quad L_2 = \rho(F_2),$$

$$F = F_1 + F_2, \quad L = L_1 = L_2.$$

(L, F) : **‘manifest’**, (L_1, F_1, L_2, F_2) : **‘latent’** variables.

After elimination of the latent variables:

$$\mathcal{B} = \{(L, F) \mid \exists \alpha : L = \rho_1(\alpha) = \rho_2(F - \alpha)\}.$$

Latent variables are **not easily eliminated in this case.**

Linear springs: $L_1 = L_1^* + \rho_1 F_1, L_2 = L_2^* + \rho_2 F_2,$

$$\rightsquigarrow L = \frac{\rho_2}{\rho_1 + \rho_2} L_1^* + \frac{\rho_1}{\rho_1 + \rho_2} L_2^* + \frac{\rho_1 \rho_2}{\rho_1 + \rho_2} F.$$

What springs teach us

- ▶ **First principles models invariably contain latent variables, in addition the manifest variables the model aims at.**
- ▶ **It may be impossible to eliminate latent variables, even for simple models.**
- ▶ **Be careful about claiming what variable ‘causes’ what. For a simple spring we may think of the force as causing the length, but this situation is already not robust under parallel connection of two such springs.**

What springs teach us

- ▶ **First principles models invariably contain latent variables, in addition the manifest variables the model aims at.**
- ▶ **It may be impossible to eliminate latent variables, even for simple models.**
- ▶ **Be careful about claiming what variable ‘causes’ what. For a simple spring we may think of the force as causing the length, but this situation is already not robust under parallel connection of two such springs.**

We now illustrate the emergence and elimination of latent variables for dynamical systems.

A mass-spring system

Two masses connected by a spring

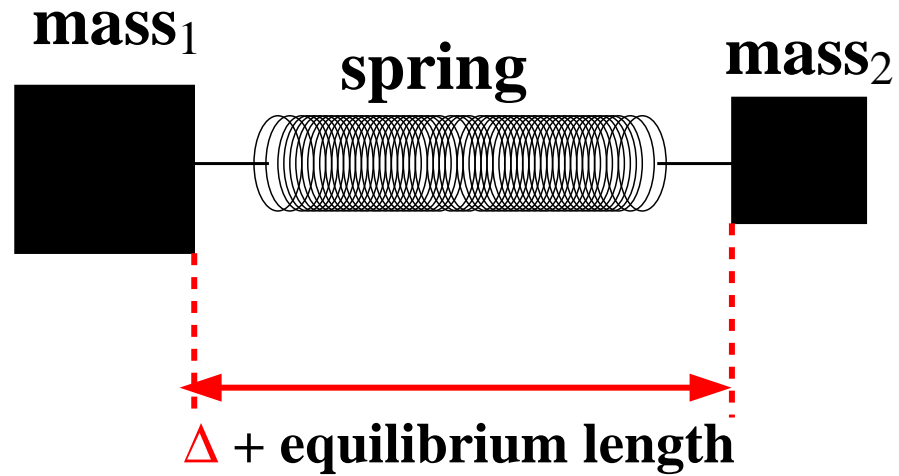

!! Model the behavior of Δ !!

Two masses connected by a spring

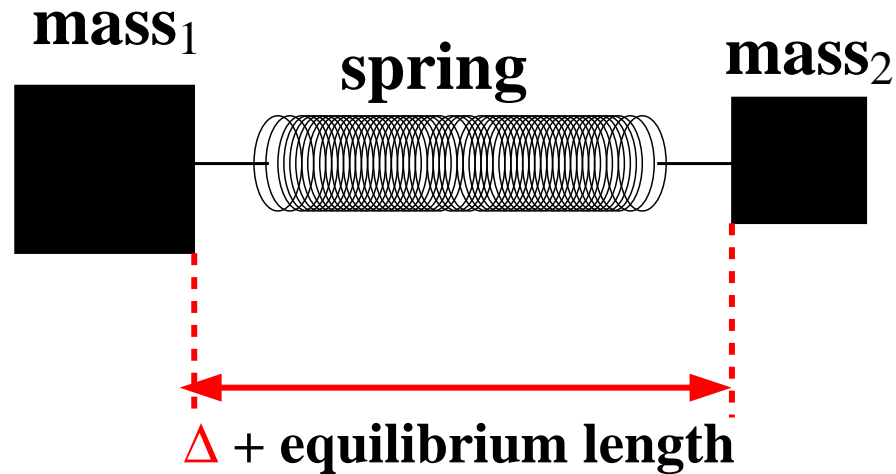

!! Model the behavior of Δ !!

View as interconnection of 3 systems.

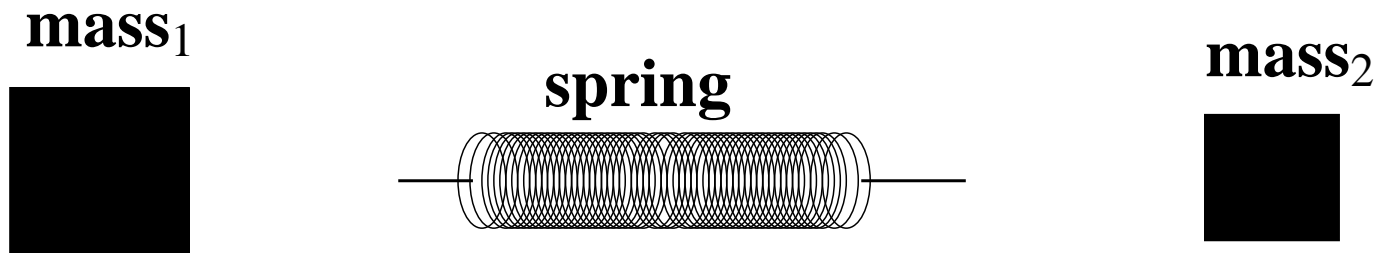

Behavioral equations

Now interconnect:

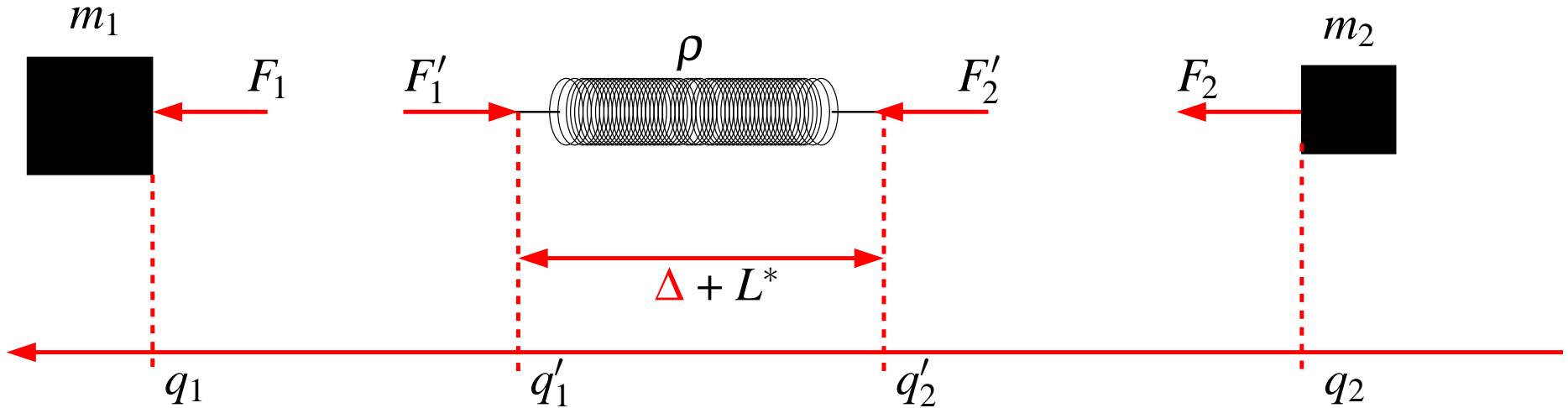

Constitutive equations:

$$m_1 \frac{d^2}{dt^2} q_1 = F_1, \quad m_2 \frac{d^2}{dt^2} q_2 = F_2, \quad q'_1 - q'_2 = L^* - \rho F'_1, \quad F'_1 = F'_2,$$

with m_1 and m_2 the masses, ρ the elasticity coefficient of the spring, and L^* is equilibrium length.

Assume that the spring operates in its linear regime.

Behavioral equations

Now interconnect:

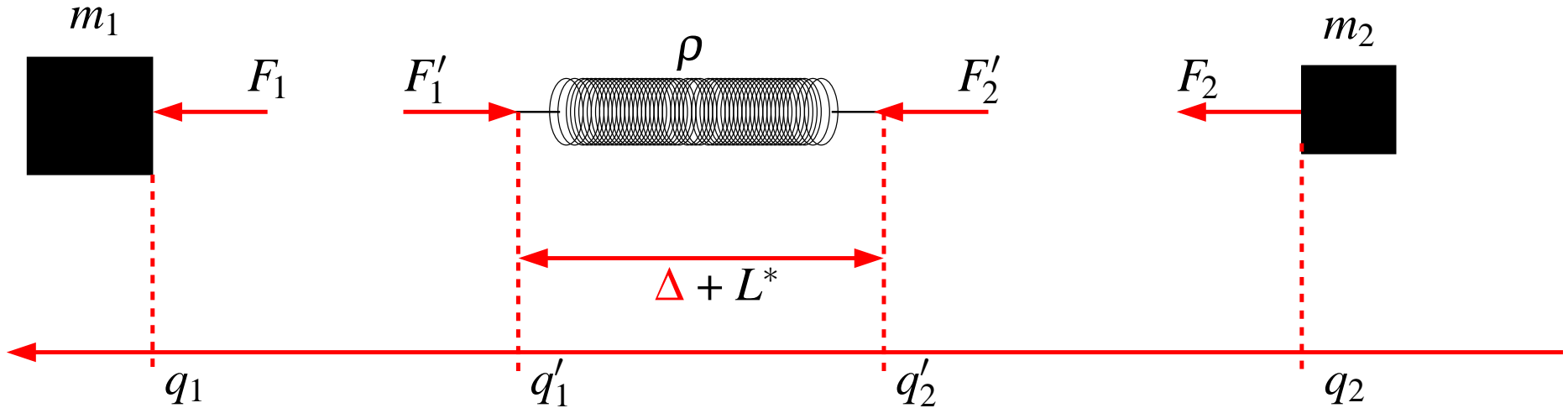

Constitutive equations:

$$m_1 \frac{d^2}{dt^2} q_1 = F_1, \quad m_2 \frac{d^2}{dt^2} q_2 = F_2, \quad q'_1 - q'_2 = L^* - \rho F'_1, \quad F'_1 = F'_2,$$

Interconnection equations:

$$F_1 = F'_1, \quad F_2 + F'_2 = 0, \quad q_1 = q'_1, \quad q_2 = q'_2.$$

Behavioral equations

Now interconnect:

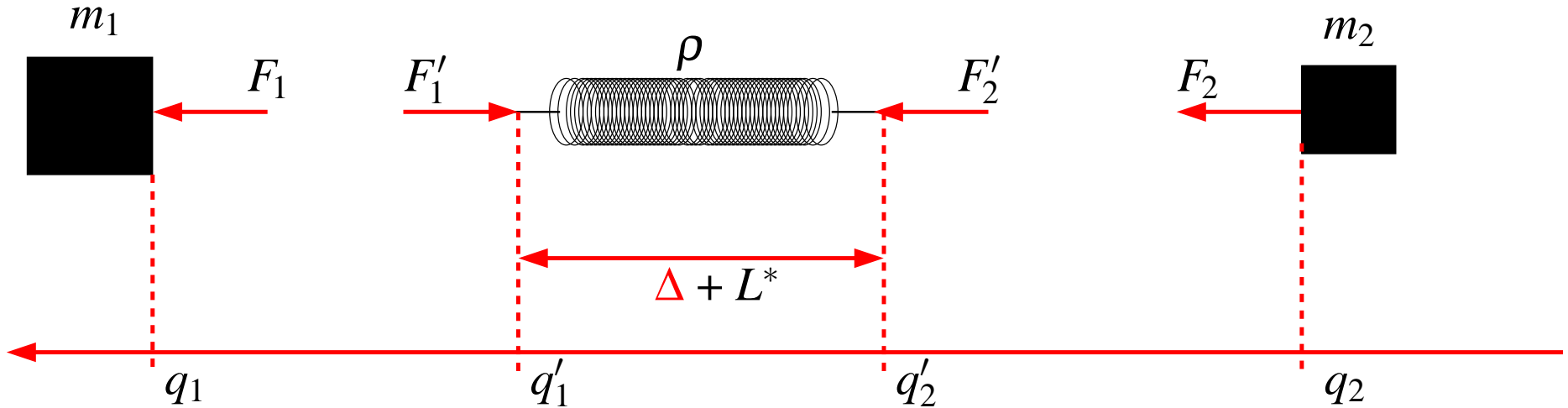

Constitutive equations:

$$m_1 \frac{d^2}{dt^2} q_1 = F_1, \quad m_2 \frac{d^2}{dt^2} q_2 = F_2, \quad q_1' - q_2' = L^* - \rho F_1', \quad F_1' = F_2',$$

Interconnection equations:

$$F_1 = F_1', \quad F_2 + F_2' = 0, \quad q_1 = q_1' \quad q_2 = q_2'.$$

Manifest variable:

$$\Delta = q_1 - q_2 - L^*.$$

Manifest behavior

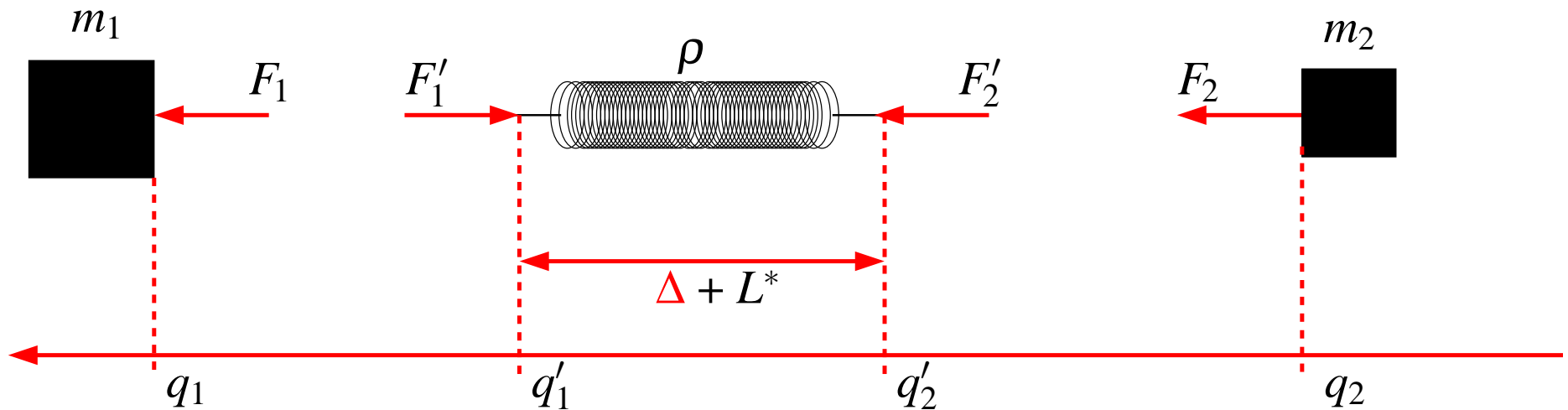

After elimination of the latent variables

$F_1, F_2, F'_1, F'_2, q_1, q_2, q'_1, q'_2$, the following equation is obtained for the manifest variable Δ

$$\frac{m_1 m_2}{m_1 + m_2} \frac{d^2}{dt^2} \Delta + \frac{1}{\rho} \Delta = 0.$$

An RLC circuit

RLC circuit

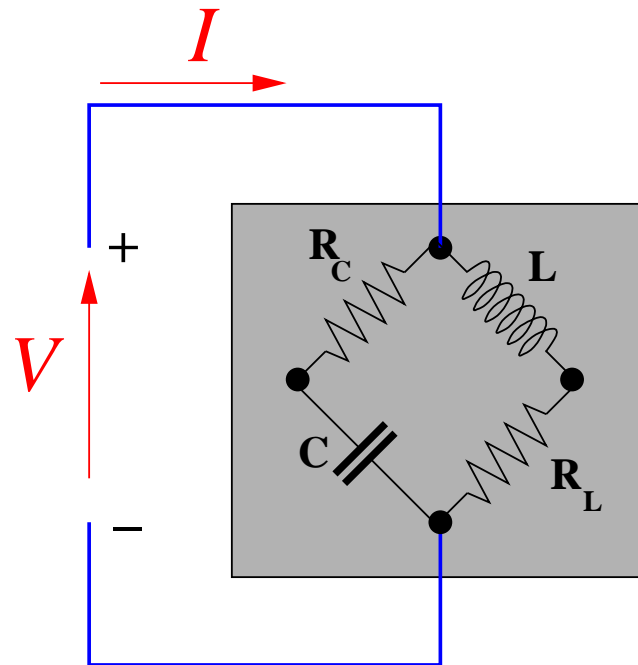

Model the port behavior of this circuit!

RLC circuit

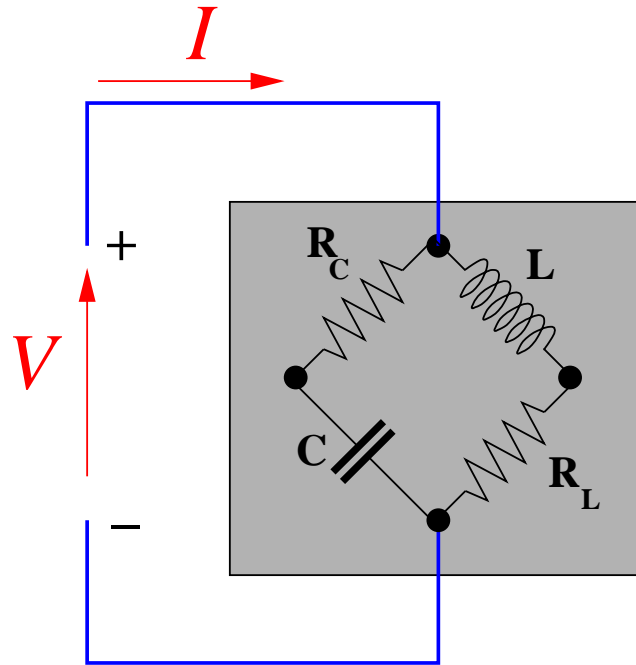

Model the port behavior of this circuit!

Manifest variables: V , the port voltage, and I , the port current.

$$\mathbb{T} = \mathbb{R}, \mathbb{W} = \mathbb{R}^2, w = \begin{bmatrix} V \\ I \end{bmatrix}.$$

Choice of latent variables

To model this circuit, we use **nodal analysis**.

Associate a digraph with the circuit:

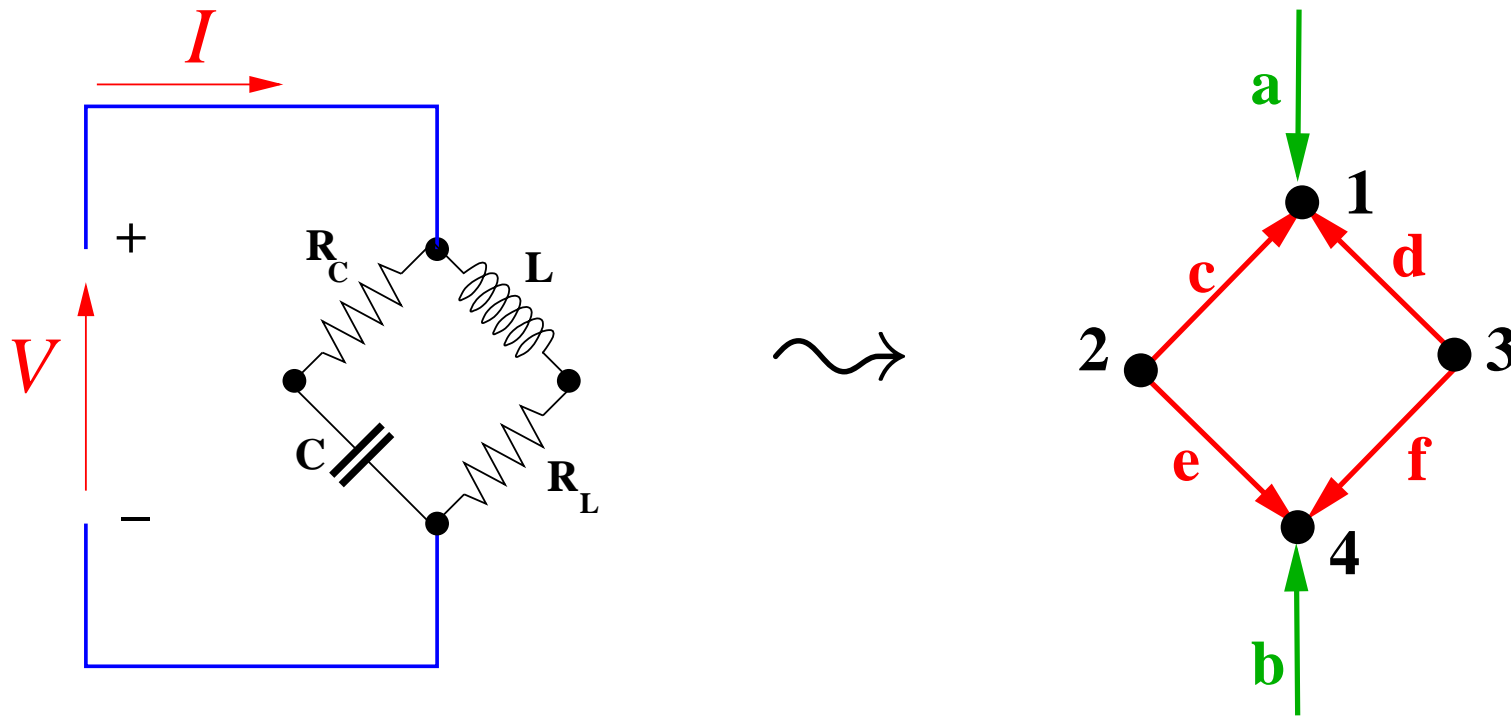

Latent variables: **potentials** of vertices, currents in edges:

$$(V_1, V_2, V_3, V_4), (I_a, I_b, I_c, I_d, I_e, I_f).$$

Behavioral equations

KCL:

vertex 1: $I_a + I_c + I_d = 0,$

vertex 2: $I_c + I_e = 0,$

vertex 3: $I_d + I_f = 0,$

vertex 4: $I_b + I_e + I_f = 0.$

Behavioral equations

KCL:

$$\text{vertex 1:} \quad I_a + I_c + I_d = 0,$$

$$\text{vertex 2:} \quad I_c + I_e = 0,$$

$$\text{vertex 3:} \quad I_d + I_f = 0,$$

$$\text{vertex 4:} \quad I_b + I_e + I_f = 0.$$

Constitutive equations:

$$\text{edge c:} \quad V_2 - V_1 = R_C I_c,$$

$$\text{edge d:} \quad V_3 - V_1 = L \frac{d}{dt} I_d,$$

$$\text{edge e:} \quad C \frac{d}{dt} (V_2 - V_4) = I_e,$$

$$\text{edge f:} \quad V_3 - V_4 = R_L I_f.$$

Behavioral equations

KCL:

$$\text{vertex 1:} \quad I_a + I_c + I_d = 0,$$

$$\text{vertex 2:} \quad I_c + I_e = 0,$$

$$\text{vertex 3:} \quad I_d + I_f = 0,$$

$$\text{vertex 4:} \quad I_b + I_e + I_f = 0.$$

Constitutive equations:

$$\text{edge c:} \quad V_2 - V_1 = R_C I_c,$$

$$\text{edge d:} \quad V_3 - V_1 = L \frac{d}{dt} I_d,$$

$$\text{edge e:} \quad C \frac{d}{dt} (V_2 - V_4) = I_e,$$

$$\text{edge f:} \quad V_3 - V_4 = R_L I_f.$$

Manifest variables:

$$\text{port voltage:} \quad V = V_1 - V_4,$$

$$\text{port current:} \quad I = I_a.$$

Behavioral equations

In total, **10** latent variables: $(V_1, V_2, V_3, V_4, I_a, I_b, I_c, I_d, I_e, I_f)$,
2 manifest variables: (V, I) ,
and **10** equations.

Behavioral equations

In total, **10** latent variables: $(V_1, V_2, V_3, V_4, I_a, I_b, I_c, I_d, I_e, I_f)$,
2 manifest variables: (V, I) ,
and **10** equations.

Which equations govern (V, I) ?

A straightforward calculation (left as an exercise) leads to the following answer.

The port behavior

The port behavior is described by the following ODE:

Case 1:

$$CR_C \neq \frac{L}{R_L}$$

$$\begin{aligned} \left(\frac{R_C}{R_L} + \left(1 + \frac{R_C}{R_L} \right) CR_C \frac{d}{dt} + CR_C \frac{L}{R_L} \frac{d^2}{dt^2} \right) V \\ = \left(1 + CR_C \frac{d}{dt} \right) \left(1 + \frac{L}{R_L} \frac{d}{dt} \right) R_C I; \end{aligned}$$

Case 2:

$$CR_C = \frac{L}{R_L}$$

$$\left(\frac{R_C}{R_L} + CR_C \frac{d}{dt} \right) V = \left(1 + CR_C \frac{d}{dt} \right) R_C I$$

The port behavior

- ▶ The behavioral equations after elimination tell *exactly* what the port behavior is.
There are no hidden assumptions.
- ▶ Next, we prove that complete elimination of the latent variables is always possible in the class of linear constant coefficient differential equations.
It is a theorem!
The RLC circuit illustrates this in a particular example.
- ▶ The different cases show that elimination is not a trivial matter. The order of the differential equation may change with the element values, etc.

The elimination theorem

Elimination problem

Assume that the (equations specifying the) extended behavior $\mathcal{B}_{\text{extended}}$ has a certain structure.

Does the manifest behavior \mathcal{B} retain this structure?

Elimination problem

Assume that the (equations specifying the) extended behavior $\mathcal{B}_{\text{extended}}$ has a certain structure.

Does the manifest behavior \mathcal{B} retain this structure?

‘Structure’: linearity, open, closed, (semi-)algebraic variety, polyhedron, solution set of ODEs, behavior of LTIDS, ...

Elimination problem

Assume that the (equations specifying the) extended behavior $\mathcal{B}_{\text{extended}}$ has a certain structure.

Does the manifest behavior \mathcal{B} retain this structure?

‘Structure’: linearity, open, closed, (semi-)algebraic variety, polyhedron, solution set of ODEs, behavior of LTIDS, ...

We have illustrate the emergence of latent variables, and their elimination in a few examples.

Projection

Consider the dynamical system $\Sigma = (\mathbb{T}, \mathbb{W}_1 \times \mathbb{W}_2, \mathcal{B})$.

Define the **projection** $\Sigma_1 = (\mathbb{T}, \mathbb{W}_1, \mathcal{B}_1)$ with

$$\mathcal{B}_1 = \{w_1 : \mathbb{T} \rightarrow \mathbb{W}_1 \mid \exists w_2 : \mathbb{T} \rightarrow \mathbb{W}_2 \text{ such that } (w_1, w_2) \in \mathcal{B}\}.$$

In the LTIDS case, $\mathcal{B} \in \mathcal{L}^{\mathbb{W}_1 + \mathbb{W}_2}$, $\mathcal{B} \subseteq \mathcal{C}^\infty(\mathbb{R}, \mathbb{R}^{\mathbb{W}_1 + \mathbb{W}_2})$.

Therefore, $\mathcal{B}_1 \subseteq \mathcal{C}^\infty(\mathbb{R}, \mathbb{R}^{\mathbb{W}_1})$.

Projection

Consider the dynamical system $\Sigma = (\mathbb{T}, \mathbb{W}_1 \times \mathbb{W}_2, \mathcal{B})$.

Define the **projection** $\Sigma_1 = (\mathbb{T}, \mathbb{W}_1, \mathcal{B}_1)$ with

$$\mathcal{B}_1 = \{w_1 : \mathbb{T} \rightarrow \mathbb{W}_1 \mid \exists w_2 : \mathbb{T} \rightarrow \mathbb{W}_2 \text{ such that } (w_1, w_2) \in \mathcal{B}\}.$$

In the LTIDS case, $\mathcal{B} \in \mathcal{L}^{\mathbb{W}_1 + \mathbb{W}_2}$, $\mathcal{B} \subseteq \mathcal{C}^\infty(\mathbb{R}, \mathbb{R}^{\mathbb{W}_1 + \mathbb{W}_2})$.

Therefore, $\mathcal{B}_1 \subseteq \mathcal{C}^\infty(\mathbb{R}, \mathbb{R}^{\mathbb{W}_1})$.

The question which we consider is if, when Σ is a LTIDS, Σ_1 is also a LTIDS. In other words,

$$[[\mathcal{B} \in \mathcal{L}^{\mathbb{W}_1 + \mathbb{W}_2}]] \Rightarrow [[\mathcal{B}_1 \in \mathcal{L}^{\mathbb{W}_1}]] ?$$

In a picture

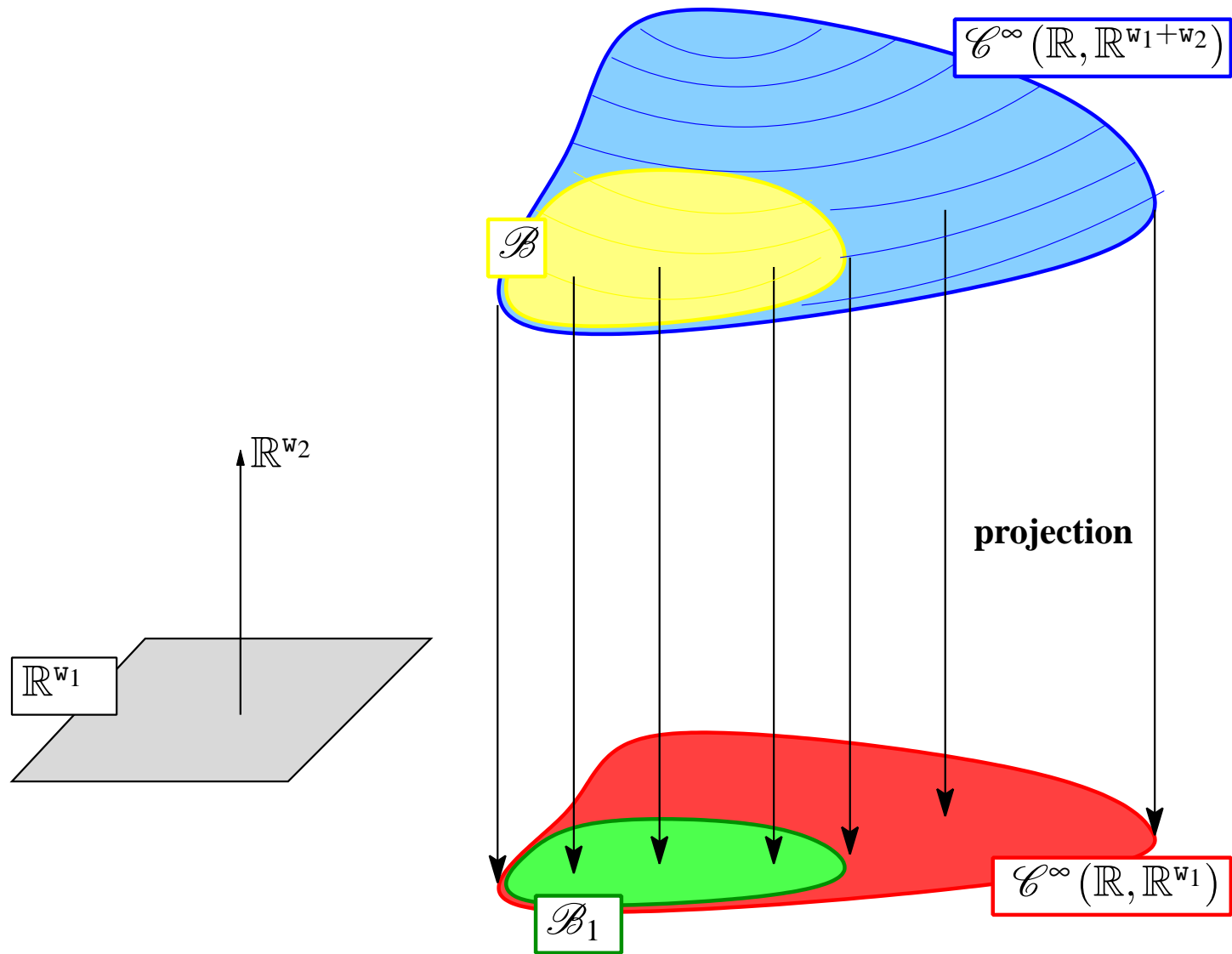

$$[\mathcal{B} \in \mathcal{L}^{w_1+w_2}] \Rightarrow [\mathcal{B}_1 \in \mathcal{L}^{w_1}] ?$$

Elimination theorem

Theorem

\mathcal{L}^\bullet is closed under projection, that is,

$$[[\mathcal{B} \in \mathcal{L}^{w_1+w_2}]] \Rightarrow [[\mathcal{B}_1 \in \mathcal{L}^{w_1}]].$$

Elimination theorem

Theorem

\mathcal{L}^\bullet is closed under projection, that is,

$$[[\mathcal{B} \in \mathcal{L}^{w_1+w_2}]] \Rightarrow [[\mathcal{B}_1 \in \mathcal{L}^{w_1}]].$$

With

$$R_1 \left(\frac{d}{dt} \right) w_1 = R_2 \left(\frac{d}{dt} \right) w_2$$

a kernel representation of \mathcal{B} , and

$$R \left(\frac{d}{dt} \right) w_1 = 0$$

a kernel representation of \mathcal{B}_1 , we think of this theorem as *‘elimination’* of the variables w_2 from the equations.

Proof in telegram-style

- ▶ Let $R_1 \left(\frac{d}{dt} \right) w_1 = R_2 \left(\frac{d}{dt} \right) w_2$ be a kernel representation of \mathcal{B} .
- ▶ Note that it can be assumed, without loss of generality, that R_2 is in Smith form,

$$R_2 = \begin{bmatrix} R'_2 \\ R''_2 \end{bmatrix} = \begin{bmatrix} \mathbf{diag}(d_1, d_2, \dots, d_r) & 0_{r \times (n_2 - r)} \\ 0_{(n_1 - r) \times r} & 0_{(n_1 - r) \times (n_2 - r)} \end{bmatrix},$$

with $d_1, d_2, \dots, d_r \neq 0$.

Proof in telegram-style

- ▶ Let $R_1 \left(\frac{d}{dt} \right) w_1 = R_2 \left(\frac{d}{dt} \right) w_2$ be a kernel representation of \mathcal{B} .
- ▶ Note that it can be assumed, without loss of generality, that R_2 is in Smith form,

$$R_2 = \begin{bmatrix} R'_2 \\ R''_2 \end{bmatrix} = \begin{bmatrix} \mathbf{diag}(d_1, d_2, \dots, d_r) & 0_{r \times (n_2 - r)} \\ 0_{(n_1 - r) \times r} & 0_{(n_1 - r) \times (n_2 - r)} \end{bmatrix},$$

with $d_1, d_2, \dots, d_r \neq 0$.

- ▶ Observe that $R'_2 \left(\frac{d}{dt} \right)$ is a surjective operator (see Proposition 4 of the section on differential operators).

Proof in telegram-style

- ▶ Let $R_1 \left(\frac{d}{dt} \right) w_1 = R_2 \left(\frac{d}{dt} \right) w_2$ be a kernel representation of \mathcal{B} .
- ▶ Note that it can be assumed, without loss of generality, that R_2 is in Smith form,

$$R_2 = \begin{bmatrix} R'_2 \\ R''_2 \end{bmatrix} = \begin{bmatrix} \mathbf{diag}(d_1, d_2, \dots, d_r) & 0_{r \times (n_2 - r)} \\ 0_{(n_1 - r) \times r} & 0_{(n_1 - r) \times (n_2 - r)} \end{bmatrix},$$

with $d_1, d_2, \dots, d_r \neq 0$.

- ▶ Observe that $R'_2 \left(\frac{d}{dt} \right)$ is a surjective operator (see Proposition 4 of the section on differential operators).
- ▶ Partition $R_1 = \begin{bmatrix} R'_1 \\ R''_1 \end{bmatrix}$ conformably to $R_2 = \begin{bmatrix} R'_2 \\ R''_2 \end{bmatrix}$.

Then $R''_1 \left(\frac{d}{dt} \right) w_1 = 0$ is a kernel representation of \mathcal{B}_1 .

Applications of the elimination theorem

- ▶ **Elimination of state variables (x) in input/state/output systems:**

$$\frac{d}{dt}x = Ax + Bu, y = Cx + Du, \rightsquigarrow P \left(\frac{d}{dt} \right) y = Q \left(\frac{d}{dt} \right) u.$$

- ▶ **Elimination of nuisance variables (x) in DAEs:**

$$E \frac{d}{dt}x = Ax + Bw \rightsquigarrow R \left(\frac{d}{dt} \right) w = 0.$$

Applications of the elimination theorem

- ▶ **Elimination of state variables (x) in input/state/output systems:**

$$\frac{d}{dt}x = Ax + Bu, y = Cx + Du, \rightsquigarrow P \left(\frac{d}{dt} \right) y = Q \left(\frac{d}{dt} \right) u.$$

- ▶ **Elimination of nuisance variables (x) in DAEs:**

$$E \frac{d}{dt}x = Ax + Bw \rightsquigarrow R \left(\frac{d}{dt} \right) w = 0.$$

- ▶ **Elimination of latent variables (ℓ):**

$$R \left(\frac{d}{dt} \right) w = M \left(\frac{d}{dt} \right) \ell \rightsquigarrow R' \left(\frac{d}{dt} \right) w = 0.$$

Applications of the elimination theorem

- ▶ **Elimination of state variables (x) in input/state/output systems:**

$$\frac{d}{dt}x = Ax + Bu, y = Cx + Du, \rightsquigarrow P \left(\frac{d}{dt} \right) y = Q \left(\frac{d}{dt} \right) u.$$

- ▶ **Elimination of nuisance variables (x) in DAEs:**

$$E \frac{d}{dt}x = Ax + Bw \rightsquigarrow R \left(\frac{d}{dt} \right) w = 0.$$

- ▶ **Elimination of latent variables (ℓ):**

$$R \left(\frac{d}{dt} \right) w = M \left(\frac{d}{dt} \right) \ell \rightsquigarrow R' \left(\frac{d}{dt} \right) w = 0.$$

- ▶ \mathcal{L}^\bullet is closed under

intersection, addition (see Exercise III.3), and projection.

Applications of the elimination theorem

For the RLC circuit, KCL, the constitutive equations, and the manifest variable assignment: all linear constant-coefficient differential equations — most of them algebraic equations (zero-th order), but linear constant-coefficient differential equations nevertheless.

Elimination theorem \Rightarrow the latent variables (the potentials of the vertices and the currents in the edges) can be completely eliminated. \Rightarrow the port behavior is described by linear constant-coefficient differential equations.

Since there are 2 real port variables, there could be 0, 1, or 2 differential equations that govern the port behavior. We derived that the behavior is described by *one* the differential equation. To prove that there is **exactly one** for a minimal kernel representation for the port behavior requires use of the passivity properties of the circuit elements.

Applications of the elimination theorem

Some of this is readily generalized to any linear RLC circuit. The external terminal behavior will be always be described by a system of linear constant-coefficient differential equations, since all the equations that describe the extended behavior (KCL, the constitutive equations, and the manifest variable assignment) are linear constant-coefficient differential equations.

The three theorems

For LTIDSs

The following are the three main theorems for LTIDSs.

1. **Theorem 1**: There exists a **$1 \leftrightarrow 1$ relation** between \mathcal{L}^w and the $\mathbb{R}[\xi]$ -submodules of $\mathbb{R}[\xi]^w$.
2. **Theorem 2**: A LTIDS is controllable if and only if its behavior is the **image** of a linear constant-coefficient differential operator.
3. **Theorem 3**: Elimination. \mathcal{L}^\bullet is closed under projection:

$$\llbracket \mathcal{B} \in \mathcal{L}^{w_1+w_2} \rrbracket \Rightarrow \llbracket \Pi_1 \mathcal{B} \in \mathcal{L}^{w_1} \rrbracket.$$

Π_{w_1} defines the projection onto the first w_1 components.

For discrete-time LTIDSs

These theorems remain valid for discrete-systems.

The relevant ring for the case $\mathbb{T} = \mathbb{Z}$ is $\mathbb{R}[\xi, \xi^{-1}]$.

For PDEs

These theorems also remain valid for systems described by linear constant-coefficient PDEs with

- ▶ **the relevant ring $\mathbb{R} [\xi_1, \xi_2, \dots, \xi_n]$,**
- ▶ **the appropriate notion of controllability.**

n-D controllability

$\llbracket (\mathbb{R}^n, \mathbb{R}^w, \mathcal{B}) \text{ is } \mathbf{controllable} \rrbracket \Leftrightarrow \llbracket \forall w_1, w_2 \in \mathcal{B}, \text{ and } \forall \text{ open subsets } O_1, O_2 \subset \mathbb{R}^n \text{ with non-intersecting closures, } \exists w \in \mathcal{B} \text{ such that}$

$$w|_{O_1} = w_1|_{O_1} \quad \mathbf{and} \quad w|_{O_2} = w_2|_{O_2} \rrbracket.$$

n-D controllability

$\llbracket (\mathbb{R}^n, \mathbb{R}^w, \mathcal{B}) \text{ is controllable} \rrbracket \Leftrightarrow \llbracket \forall w_1, w_2 \in \mathcal{B}, \text{ and } \forall \text{ open subsets } O_1, O_2 \subset \mathbb{R}^n \text{ with non-intersecting closures, } \exists w \in \mathcal{B} \text{ such that}$

$$w|_{O_1} = w_1|_{O_1} \quad \text{and} \quad w|_{O_2} = w_2|_{O_2} \rrbracket.$$

This definition is illustrated in the picture below.

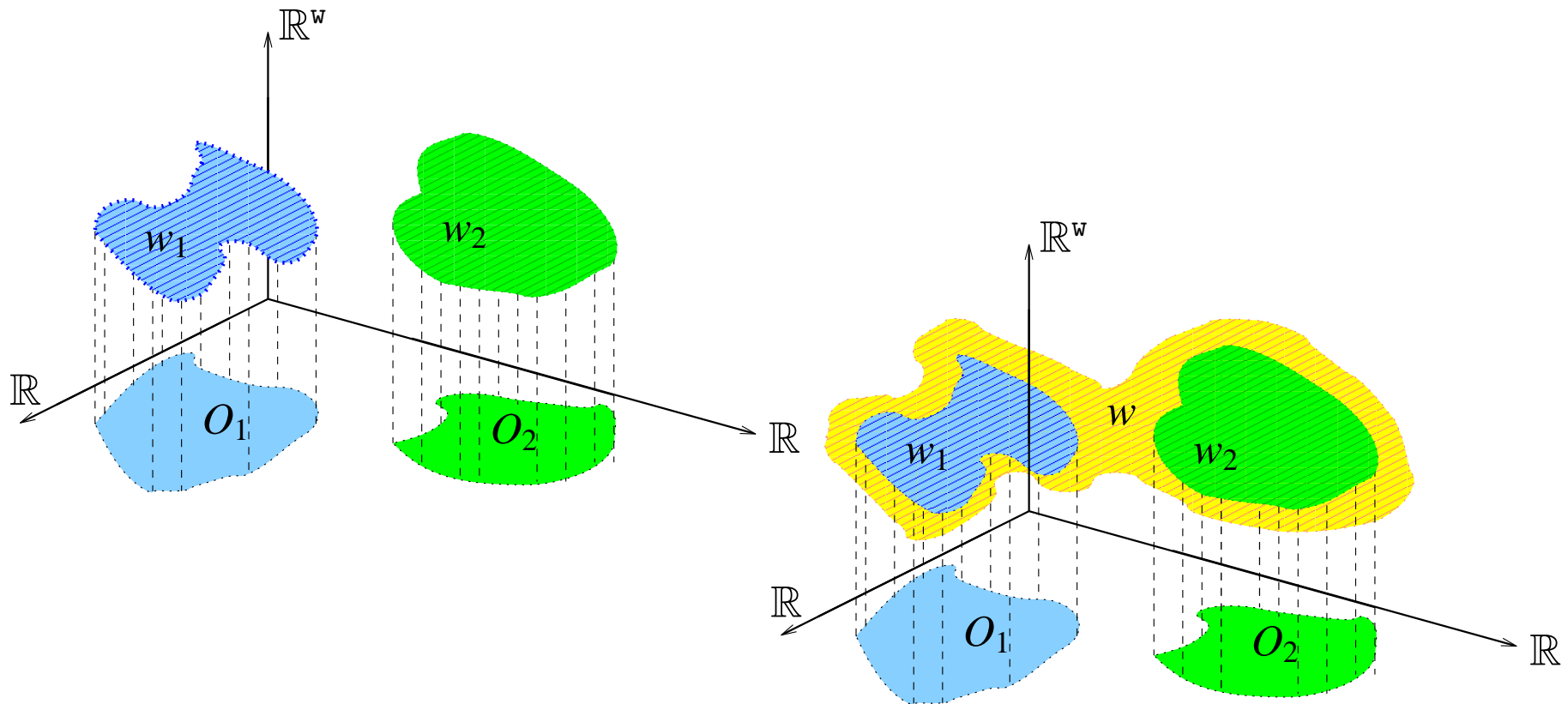

State representations

The ubiquitous input/output/state systems

- ▶ **Are input/state/output state representations**

$$\frac{d}{dt}x = f(y, u), y = h(x, u); \quad \frac{d}{dt}x = Ax + Bu, y = Cx + Du$$

a ‘natural’ starting point for modeling?

The ubiquitous input/output/state systems

- ▶ **Are input/state/output state representations**

$$\frac{d}{dt}x = f(y, u), \quad y = h(x, u); \quad \frac{d}{dt}x = Ax + Bu, \quad y = Cx + Du$$

a ‘natural’ starting point for modeling?

- ▶ **Mechanics \rightsquigarrow 2nd order differential equations.
SYSID, transfer functions \rightsquigarrow high-order equations.**
- ▶ **First principles modeling and
‘tearing, zooming, and linking’ (see Lecture IV)
 \rightsquigarrow latent variables,**
- ▶ **Invariably, there are algebraic constraints among
variables.**

The ubiquitous input/output/state systems

- ▶ Are input/state/output state representations a ‘natural’ starting point for modeling?

No Way!

The ubiquitous input/output/state systems

- ▶ **Are state representations important?**

The ubiquitous input/output/state systems

- ▶ **Are state representations important?**
- ▶ **1st-order, i/o partition \rightsquigarrow initial condition, simulation.**
- ▶ **1st-order \rightsquigarrow algorithms based on linear algebra.**
- ▶ **Sometimes, ‘state’ is natural: think charges on capacitors & fluxes in inductors in electric circuits, positions & momenta in mechanics, Markov processes, state in QM, etc.**

The ubiquitous input/output/state systems

- ▶ Are state representations important?

You bet!

Issues

- ▶ **What is a first principles definition of ‘state?’**
- ▶ **What does that imply for the equations?**

Issues

- ▶ **What is a first principles definition of ‘state?’**
- ▶ **What does that imply for the equations?**
- ▶ **Is it possible to derive a state variable from the equations?**
- ▶ **Give algorithms for state representation.**

The notion of state

State and concatenation

Notation:

A dynamical system is denoted as $(\mathbb{T}, \mathbb{W}, \mathcal{B})$.

A dynamical system with latent variables is denoted as

$$(\mathbb{T}, \mathbb{W}, \mathbb{L}, \mathcal{B}_{\text{full}})$$

with \mathbb{L} the space of latent variables,
 $\mathcal{B}_{\text{full}}$ the ‘full’ behavior.

After projection (elimination) $\rightsquigarrow (\mathbb{T}, \mathbb{W}, \mathcal{B})$
 \mathcal{B} = the ‘manifest behavior’.

For state models, however, we denote \mathbb{L} by \mathbb{X} instead.

State and concatenation

$\Sigma = (\mathbb{T}, \mathbb{W}, \mathbb{X}, \mathcal{B}_{\text{full}})$, $\mathcal{B}_{\text{full}} \in (\mathbb{W} \times \mathbb{X})^{\mathbb{T}}$, is a **state system** if

$$\llbracket (w_1, x_1), (w_2, x_2) \in \mathcal{B}_{\text{full}} \textbf{ and } x_1(t) = x_2(t) \rrbracket$$

\Downarrow

$$\llbracket (w_1, x_1) \underset{T}{\wedge} (w_2, x_2) \in \mathcal{B}_{\text{full}} \rrbracket$$

$\underset{t}{\wedge}$ denotes *concatenation at t*:

$$(f_1 \underset{t}{\wedge} f_2)(t') := \begin{cases} f_1(t') \textbf{ for } t' < t \\ f_2(t') \textbf{ for } t' \geq t \end{cases}$$

State in a picture

$$(w_1, x_1), (w_2, x_2) \in \mathcal{B}_{\text{full}} \quad \text{and} \quad x_1(t) = x_2(t)$$



$$(w_1, x_1) \underset{t}{\wedge} (w_2, x_2) \in \mathcal{B}_{\text{full}}$$

State in a picture

$$(w_1, x_1), (w_2, x_2) \in \mathcal{B}_{\text{full}} \quad \text{and} \quad x_1(t) = x_2(t)$$



$$(w_1, x_1) \underset{t}{\wedge} (w_2, x_2) \in \mathcal{B}_{\text{full}}$$

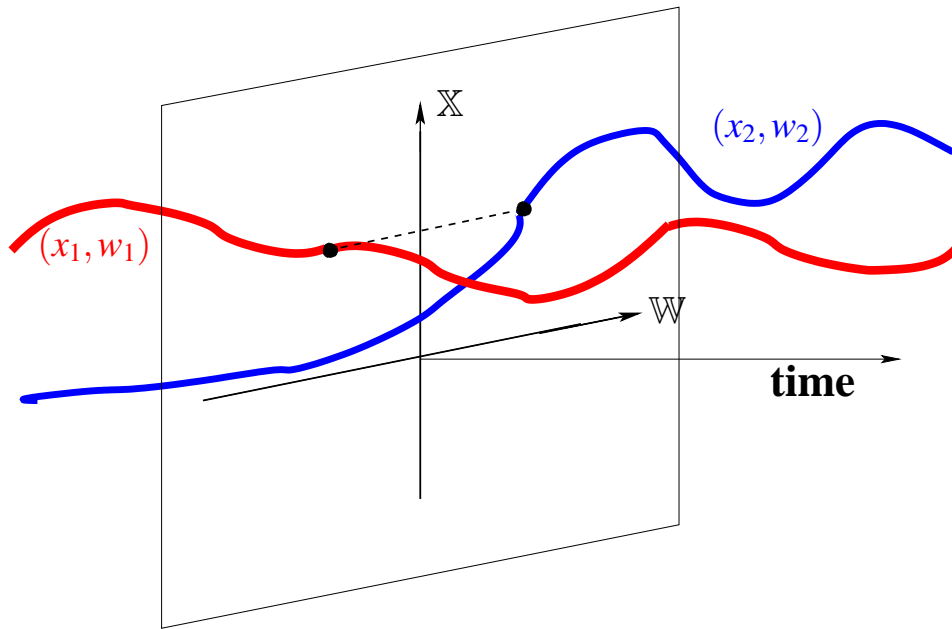

State in a picture

$$(w_1, x_1), (w_2, x_2) \in \mathcal{B}_{\text{full}} \quad \text{and} \quad x_1(t) = x_2(t)$$



$$(w_1, x_1) \underset{t}{\wedge} (w_2, x_2) \in \mathcal{B}_{\text{full}}$$

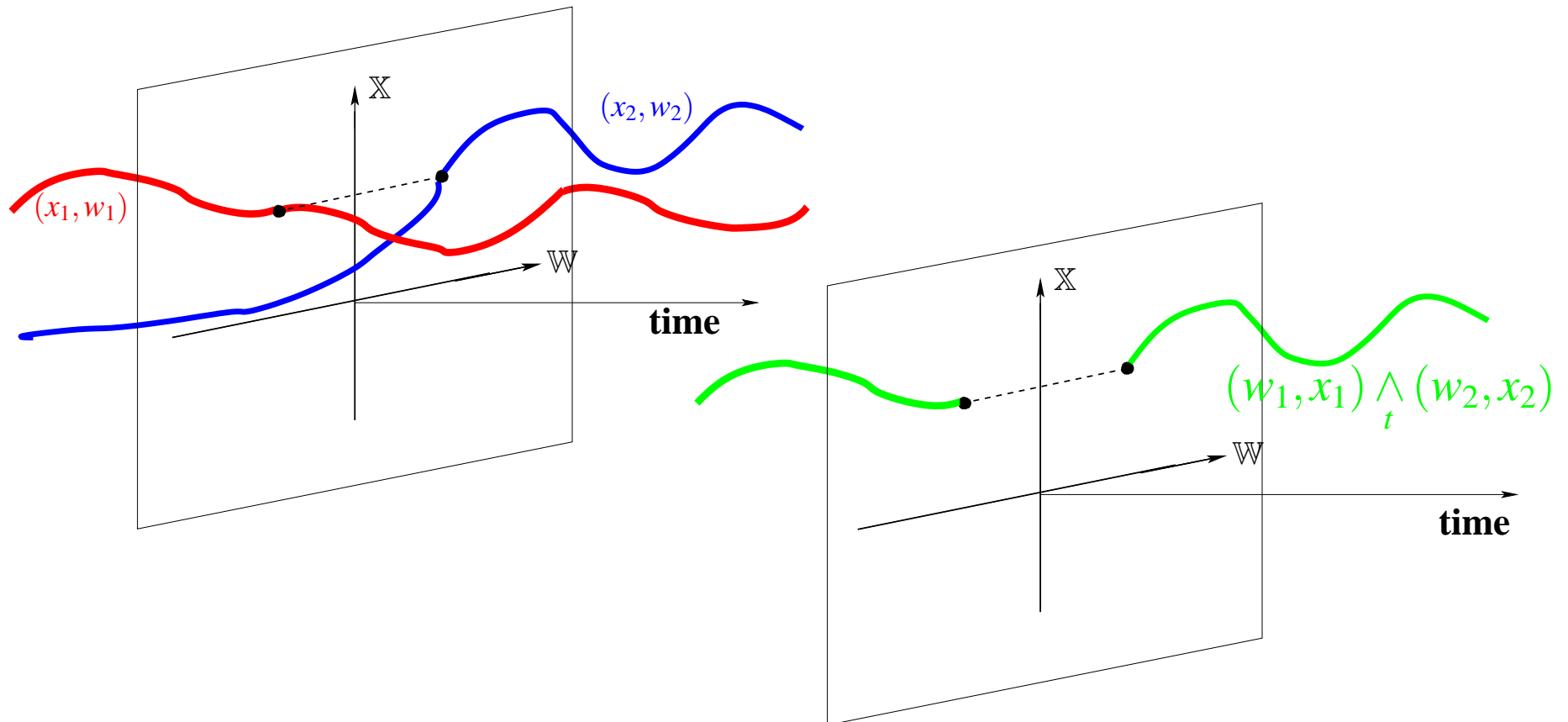

Discrete-time first-order representations

Theorem: A ‘complete’ latent variable system

$$(\mathbb{Z}, \mathbb{W}, \mathbb{X}, \mathcal{B}_{\text{full}})$$

is a state system if and only if $\mathcal{B}_{\text{full}}$ can be described by

$$f \circ (\sigma x, x, w) = 0$$

0-th order in w , 1st order in x .

Discrete-time first-order representations

Theorem: A ‘complete’ latent variable system

$$(\mathbb{Z}, \mathbb{W}, \mathbb{X}, \mathcal{B}_{\text{full}})$$

is a state system if and only if $\mathcal{B}_{\text{full}}$ can be described by

$$f \circ (\sigma x, x, w) = 0$$

0-th order in w , 1st order in x .

Linear case:

$$E \sigma x + F x + G w = 0$$

E, F, G matrices.

1st order in x is the essence of the state property!

State maps

State construction for discrete-time systems: basic idea

Problem: Given a kernel (or image or other) representation of $\mathcal{B} \in \mathcal{L}^w$, find a state representation

$$E\sigma x + Fx + Gw = 0$$

with manifest behavior \mathcal{B} .

State construction for discrete-time systems: basic idea

Problem: Given a kernel (or image or other) representation of $\mathcal{B} \in \mathcal{L}^w$, find a state representation

$$E\sigma x + Fx + Gw = 0$$

with manifest behavior \mathcal{B} .

Strategy: First compute polynomial operator in the shift acting on the system variables, inducing a state variable:

$$x = X(\sigma)w.$$

$X(\sigma)$ is called a **state map**

Then use the original equations and X to obtain 1st order representation.

State maps for discrete-time kernel representations

$X \in \mathbb{R}^{\bullet \times w}[\xi]$ induces a *state map* $X(\sigma)$ for $\text{kernel}(R(\sigma))$ if the behavior $\mathcal{B}_{\text{full}}$ with latent variable x , consisting of all (w, x) such that

$$\begin{aligned} R(\sigma)w &= 0 \\ X(\sigma)w &= x \end{aligned}$$

satisfies the state property.

State maps for discrete-time kernel representations

$X \in \mathbb{R}^{\bullet \times w}[\xi]$ induces a *state map* $X(\sigma)$ for $\text{kernel}(R(\sigma))$ if the behavior $\mathcal{B}_{\text{full}}$ with latent variable x , consisting of all (w, x) such that

$$\begin{aligned} R(\sigma)w &= 0 \\ X(\sigma)w &= x \end{aligned}$$

satisfies the state property.

- ▶ State maps exist.
- ▶ Minimality (dimension of state space as small as possible).
- ▶ State map \rightsquigarrow state representation.

Minimal state maps

State system $(\mathbb{R}, \mathbb{R}^w, \mathbb{R}^n, \mathcal{B}_f)$ is **(state)-minimal** if every other state system $(\mathbb{R}, \mathbb{R}^w, \mathbb{R}^{n'}, \mathcal{B}'_f)$ with same external behavior is such that $n' \geq n$

Minimal state dimension: $n(\mathcal{B})$,
the **'McMillan degree'** of \mathcal{B} (see Exercise III.6).

Minimal state maps

State system $(\mathbb{R}, \mathbb{R}^w, \mathbb{R}^n, \mathcal{B}_f)$ is **(state)-minimal** if every other state system $(\mathbb{R}, \mathbb{R}^w, \mathbb{R}^{n'}, \mathcal{B}'_f)$ with same external behavior is such that $n' \geq n$

Minimal state dimension: $n(\mathcal{B})$,

the **'McMillan degree'** of \mathcal{B} (see Exercise III.6).

Minimal state map \rightsquigarrow minimal state variable

Minimal state maps

State system $(\mathbb{R}, \mathbb{R}^w, \mathbb{R}^n, \mathcal{B}_f)$ is **(state)-minimal** if every other state system $(\mathbb{R}, \mathbb{R}^w, \mathbb{R}^{n'}, \mathcal{B}'_f)$ with same external behavior is such that $n' \geq n$

Minimal state dimension: $n(\mathcal{B})$,

the **'McMillan degree'** of \mathcal{B} (see Exercise III.6).

Minimal state map \rightsquigarrow minimal state variable

Minimality of $(\mathbb{R}, \mathbb{R}^w, \mathbb{R}^n, \mathcal{B}_f)$ equivalent with:

- ▶ **Trimness:** for every $x_0 \in \mathbb{R}^n$ exists $(w, x) \in \mathcal{B}_f$ such that $x(0) = x_0$;

Minimal state maps

State system $(\mathbb{R}, \mathbb{R}^w, \mathbb{R}^n, \mathcal{B}_f)$ is **(state)-minimal** if every other state system $(\mathbb{R}, \mathbb{R}^w, \mathbb{R}^{n'}, \mathcal{B}'_f)$ with same external behavior is such that $n' \geq n$

Minimal state dimension: $n(\mathcal{B})$,

the **'McMillan degree'** of \mathcal{B} (see Exercise III.6).

Minimal state map \rightsquigarrow minimal state variable

Minimality of $(\mathbb{R}, \mathbb{R}^w, \mathbb{R}^n, \mathcal{B}_f)$ equivalent with:

- ▶ **Trimness:** for every $x_0 \in \mathbb{R}^n$ exists $(w, x) \in \mathcal{B}_f$ such that $x(0) = x_0$;
- ▶ **Observability** of x from $w \Leftrightarrow$ exists $X \in \mathbb{R}^{n \times w}[\xi]$ s.t. $x = X(\sigma)w$.

The shift-and-cut map

The state property revisited

A **linear** system $\Sigma = (\mathbb{T}, \mathbb{W}, \mathbb{X}, \mathcal{B}_{\text{full}})$ with latent variable x is a state system if

$$(w, x) \in \mathcal{B}_{\text{full}} \text{ and } x(t) = 0$$



$$(0, 0) \underset{t}{\wedge} (w, x) \in \mathcal{B}_{\text{full}}$$

- ▶ **Time-invariance** \Rightarrow can choose $T = 0$;
- ▶ **Concatenability with 0 trajectory** is key;

When is $w \in \mathcal{B}$ concatenable with $\mathbf{0}$?

$$R_0 w + R_1 \sigma w + \dots + R_L \sigma^L w = 0$$

| | | | | | | | |
|-----|----------|----------|---------|---------|---------|---------|-----|
| ... | 0 | 0 | $w(0)$ | $w(1)$ | $w(2)$ | $w(3)$ | ... |
| ... | $k = -2$ | $k = -1$ | $k = 0$ | $k = 1$ | $k = 2$ | $k = 3$ | ... |

When is $w \in \mathcal{B}$ concatenable with $\mathbf{0}$?

$$R_0 w + R_1 \sigma w + \dots + R_L \sigma^L w = 0$$

\dots $\mathbf{0}$ $\mathbf{0}$ R_0 R_1 R_2 R_3 \dots

| | | | | | | | |
|---------|--------------|--------------|---------|---------|---------|---------|---------|
| \dots | $\mathbf{0}$ | $\mathbf{0}$ | $w(0)$ | $w(1)$ | $w(2)$ | $w(3)$ | \dots |
| \dots | $k = -2$ | $k = -1$ | $k = 0$ | $k = 1$ | $k = 2$ | $k = 3$ | \dots |

$$R_0 w(0) + R_1 w(1) + \dots + R_L w(L) = 0$$

When is $w \in \mathcal{B}$ concatenable with $\mathbf{0}$?

$$R_0 w + R_1 \sigma w + \dots + R_L \sigma^L w = \mathbf{0}$$

\dots $\mathbf{0}$ R_0 R_1 R_2 R_3 R_4 \dots

| | | | | | | | |
|---------|--------------|--------------|---------|---------|---------|---------|---------|
| \dots | $\mathbf{0}$ | $\mathbf{0}$ | $w(0)$ | $w(1)$ | $w(2)$ | $w(3)$ | \dots |
| \dots | $k = -2$ | $k = -1$ | $k = 0$ | $k = 1$ | $k = 2$ | $k = 3$ | \dots |

$$R_0 w(0) + R_1 w(1) + \dots + R_L w(L) = \mathbf{0}$$

$$R_1 w(0) + R_2 w(1) + \dots + R_L w(L-1) = \mathbf{0}$$

When is $w \in \mathcal{B}$ concatenable with $\mathbf{0}$?

$$R_0 w + R_1 \sigma w + \dots + R_L \sigma^L w = 0$$

\dots R_0 R_1 R_2 R_3 R_4 R_5 \dots

| | | | | | | | |
|---------|--------------|--------------|---------|---------|---------|---------|---------|
| \dots | $\mathbf{0}$ | $\mathbf{0}$ | $w(0)$ | $w(1)$ | $w(2)$ | $w(3)$ | \dots |
| \dots | $k = -2$ | $k = -1$ | $k = 0$ | $k = 1$ | $k = 2$ | $k = 3$ | \dots |

$$R_0 w(0) + R_1 w(1) + \dots + R_L w(L) = 0$$

$$R_1 w(0) + R_2 w(1) + \dots + R_L w(L-1) = 0$$

$$R_2 w(0) + R_3 w(1) + \dots + R_L w(L-2) = 0$$

When is $w \in \mathcal{B}$ concatenable with $\mathbf{0}$?

$$R_0 w + R_1 \sigma w + \dots + R_L \sigma^L w = \mathbf{0}$$

$$\dots \quad R_{L-2} \quad R_{L-1} \quad \color{red}{R_L} \quad 0 \quad 0 \quad 0 \quad \dots$$

| | | | | | | | |
|-----|----------|----------|---------|---------|---------|---------|-----|
| ... | 0 | 0 | $w(0)$ | $w(1)$ | $w(2)$ | $w(3)$ | ... |
| ... | $k = -2$ | $k = -1$ | $k = 0$ | $k = 1$ | $k = 2$ | $k = 3$ | ... |

$$R_0 w(0) + R_1 w(1) + \dots + R_L w(L) = 0$$

$$R_1 w(0) + R_2 w(1) + \dots + R_L w(L-1) = 0$$

$$R_2 w(0) + R_3 w(1) + \dots + R_L w(L-2) = 0$$

$$\vdots = \vdots$$

$$\color{red}{R_L w(0)} = 0$$

The shift-and-cut map

$$\sigma_+ : \mathbb{R}[\xi] \rightarrow \mathbb{R}[\xi]$$

$$\sigma_+ \left(\sum_{i=0}^n p_i \xi^i \right) := \sum_{i=0}^{n-1} p_{i+1} \xi^i$$

‘Divide by ξ and keep the polynomial part’

$$p(\xi) = \frac{p(\xi) - p(0)}{\xi}.$$

Extend componentwise to vectors and matrices.

Example

$$R(\xi) = R_0 + R_1\xi + \dots + R_{L-1}\xi^{L-1} + R_L\xi^L$$

Example

$$R(\xi) = R_0 + R_1\xi + \dots + R_{L-1}\xi^{L-1} + R_L\xi^L$$

▶ $\sigma_+(R(\xi)) = R_1 + \dots + R_{L-1}\xi^{L-2} + R_L\xi^{L-1}$

Example

$$R(\xi) = R_0 + R_1\xi + \dots + R_{L-1}\xi^{L-1} + R_L\xi^L$$

▶ $\sigma_+(R(\xi)) = R_1 + \dots + R_{L-1}\xi^{L-2} + R_L\xi^{L-1}$

▶ $\sigma_+^2(R(\xi)) = R_2 + \dots + R_{L-1}\xi^{L-3} + R_L\xi^{L-2}$

Example

$$R(\xi) = R_0 + R_1\xi + \dots + R_{L-1}\xi^{L-1} + R_L\xi^L$$

▶ $\sigma_+(R(\xi)) = R_1 + \dots + R_{L-1}\xi^{L-2} + R_L\xi^{L-1}$

▶ $\sigma_+^2(R(\xi)) = R_2 + \dots + R_{L-1}\xi^{L-3} + R_L\xi^{L-2}$

▶ $\vdots = \vdots$

▶ $\sigma_+^L(R(\xi)) = R_L$

Shift-and-cut and concatenability with 0

w is
concatenable
with 0

$$\Leftrightarrow \begin{array}{rcl} (\sigma_+(R)(\sigma)w)(0) & = & 0 \\ (\sigma_+^2(R)(\sigma)w)(0) & = & 0 \\ \vdots & = & \vdots \\ (\sigma_+^L(R)(\sigma)w)(0) & = & 0 \end{array}$$

Shift-and-cut and concatenability with 0

w is
concatenable
with 0

\Leftrightarrow

$$\begin{aligned}(\sigma_+(R)(\sigma)w)(0) &= 0 \\(\sigma_+^2(R)(\sigma)w)(0) &= 0 \\&\vdots \\(\sigma_+^L(R)(\sigma)w)(0) &= 0\end{aligned}$$

Shift-and-cut and concatenability with $\mathbf{0}$

w is
concatenable
with $\mathbf{0}$

\Leftrightarrow

$$\begin{aligned}(\sigma_+(R)(\sigma)w)(\mathbf{0}) &= 0 \\(\sigma_+^2(R)(\sigma)w)(\mathbf{0}) &= 0 \\&\vdots \\(\sigma_+^L(R)(\sigma)w)(\mathbf{0}) &= 0\end{aligned}$$

$\text{col}((\sigma_+^i(R))_{i=1,\dots,L}(\sigma))$ is a state map!

Shift-and-cut and concatenability with $\mathbf{0}$

w is
concatenable
with $\mathbf{0}$

\Leftrightarrow

$$\begin{aligned}(\sigma_+(R)(\sigma)w)(\mathbf{0}) &= 0 \\(\sigma_+^2(R)(\sigma)w)(\mathbf{0}) &= 0 \\&\vdots \\&= \vdots \\(\sigma_+^L(R)(\sigma)w)(\mathbf{0}) &= 0\end{aligned}$$

$\text{col}((\sigma_+^i(R))_{i=1,\dots,L}(\sigma))$ is a state map!

From kernel representation to state map

From kernel/image representation to state map

Denote $\text{col}((\sigma_+^i(R)))_{i=1,\dots,L} =: \Sigma_R$.

Theorem: Let $\mathcal{B} = \text{kernel}(R(\sigma))$. Then

$$\begin{aligned} R(\sigma)w &= 0 \\ \Sigma_R(\sigma)w &= x \end{aligned}$$

is a **state representation** of \mathcal{B} with **state variable** x .

Nonuniqueness of state maps

Ways of expressing concatenability with $\mathbf{0}$: compare for

$$r_0 w + r_1 \sigma w + \dots + \sigma^n w = 0$$

the two systems of equations

| | |
|----------------------------------|------------------|
| w | w |
| $r_{n-1} w + \sigma w$ | σw |
| \vdots | \vdots |
| $r_1 w + \dots + \sigma^{n-1} w$ | $\sigma^{n-1} w$ |

Nonuniqueness of state maps

Ways of expressing concatenability with $\mathbf{0}$: compare for

$$r_0 w + r_1 \sigma w + \dots + \sigma^n w = 0$$

the two systems of equations

| | |
|----------------------------------|------------------|
| w | w |
| $r_{n-1} w + \sigma w$ | σw |
| \vdots | \vdots |
| $r_1 w + \dots + \sigma^{n-1} w$ | $\sigma^{n-1} w$ |

\Rightarrow **different state maps are possible!**

Nonuniqueness of state maps

Ways of expressing concatenability with $\mathbf{0}$: compare for

$$r_0 w + r_1 \sigma w + \dots + \sigma^n w = 0$$

the two systems of equations

$$\begin{array}{l} w \\ r_{n-1} w + \sigma w \\ \vdots \\ r_1 w + \dots + \sigma^{n-1} w \end{array} \qquad \begin{array}{l} w \\ \sigma w \\ \vdots \\ \sigma^{n-1} w \end{array}$$

\Rightarrow **different state maps are possible!**

¿ How to characterize this nonuniqueness ?

Algebraic characterization

Theorem: Let $\mathcal{B} = \mathbf{kernel}(R(\sigma))$, and define Σ_R as above.
Define

$$\begin{aligned}\bar{\Xi}_R &:= \{f \in \mathbb{R}^{1 \times w}[\xi] \mid \exists \alpha \in \mathbb{R}^{1 \times \bullet} \text{ s.t. } f = \alpha \Sigma_R\} \\ \langle R \rangle &:= \{f \in \mathbb{R}^{1 \times w}[\xi] \mid \exists g \in \mathbb{R}^{1 \times \bullet}[\xi] \text{ s.t. } f = gR\}\end{aligned}$$

Algebraic characterization

Theorem: Let $\mathcal{B} = \mathbf{kernel}(R(\sigma))$, and define Σ_R as above.
Define

$$\begin{aligned}\bar{\Xi}_R &:= \{f \in \mathbb{R}^{1 \times w}[\xi] \mid \exists \alpha \in \mathbb{R}^{1 \times \bullet} \text{ s.t. } f = \alpha \Sigma_R\} \\ \langle R \rangle &:= \{f \in \mathbb{R}^{1 \times w}[\xi] \mid \exists g \in \mathbb{R}^{1 \times \bullet}[\xi] \text{ s.t. } f = gR\}\end{aligned}$$

$X \in \mathbb{R}^{\bullet \times w}[\xi]$ is state map for
 $\mathbf{kernel}(R(\sigma))$

if and only if

$$\text{rowspan}_{\mathbb{R}}(X) \oplus \langle R \rangle = \bar{\Xi}_R + \langle R \rangle$$

Algebraic characterization

Theorem: Let $\mathcal{B} = \mathbf{kernel}(R(\sigma))$, and define Σ_R as above.
Define

$$\begin{aligned}\Xi_R &:= \{f \in \mathbb{R}^{1 \times w}[\xi] \mid \exists \alpha \in \mathbb{R}^{1 \times \bullet} \text{ s.t. } f = \alpha \Sigma_R\} \\ \langle R \rangle &:= \{f \in \mathbb{R}^{1 \times w}[\xi] \mid \exists g \in \mathbb{R}^{1 \times \bullet}[\xi] \text{ s.t. } f = gR\}\end{aligned}$$

$X \in \mathbb{R}^{\bullet \times w}[\xi]$ is state map for
 $\mathbf{kernel}(R(\sigma))$

if and only if

$$\text{rowspan}_{\mathbb{R}}(X) \oplus \langle R \rangle = \Xi_R + \langle R \rangle$$

X minimal iff its rows are a **basis** for complementary subspace of $\langle R \rangle$ in $\Xi_R + \langle R \rangle$.

State maps for other representations

It is possible to generalize all this to image representations and to latent variable representations.

State maps for continuous-time LTIDSs

Continuous-time systems: solution space

The state property is defined in terms of concatenation. Concatenation is not compatible with \mathcal{C}^∞ . We therefore need to enlarge the solution set for the ODEs that define LTIDSs.

$$\mathcal{L}^{\text{loc}} := \{f : \mathbb{R} \rightarrow \mathbb{R}^w \mid \int_K |f| dx \text{ finite } \forall \text{ compact } K \subset \mathbb{R}\}$$

Continuous-time systems: solution space

The state property is defined in terms of concatenation. Concatenation is not compatible with \mathcal{C}^∞ . We therefore need to enlarge the solution set for the ODEs that define LTIDSs.

$$\mathcal{L}^{\text{loc}} := \{f : \mathbb{R} \rightarrow \mathbb{R}^w \mid \int_K |f| dx \text{ finite } \forall \text{ compact } K \subset \mathbb{R}\}$$

Equality in the sense of distributions:

$$R\left(\frac{d}{dt}\right)w = 0 \quad \Leftrightarrow \quad \int_{-\infty}^{+\infty} w(t)^\top \left(R\left(-\frac{d}{dt}\right)^\top f\right)(t) dt = 0$$

for all testing functions f .

Continuous-time systems: solution space

The state property is defined in terms of concatenation. Concatenation is not compatible with \mathcal{C}^∞ . We therefore need to enlarge the solution set for the ODEs that define LTIDSs.

$$\mathcal{L}^{\text{loc}} := \{f : \mathbb{R} \rightarrow \mathbb{R}^w \mid \int_K |f| dx \text{ finite } \forall \text{ compact } K \subset \mathbb{R}\}$$

Equality in the sense of distributions:

$$R\left(\frac{d}{dt}\right)w = 0 \quad \Leftrightarrow \quad \int_{-\infty}^{+\infty} w(t)^\top \left(R\left(-\frac{d}{dt}\right)^\top f\right)(t) dt = 0$$

for all testing functions f .

Testing functions:

\mathcal{C}^∞ -functions with compact support ('blips')

Continuous-time systems: solution space

The state property is defined in terms of concatenation. Concatenation is not compatible with \mathcal{C}^∞ . We therefore need to enlarge the solution set for the ODEs that define LTIDSs.

$$\mathcal{L}^{\text{loc}} := \{f : \mathbb{R} \rightarrow \mathbb{R}^w \mid \int_K |f| dx \text{ finite } \forall \text{ compact } K \subset \mathbb{R}\}$$

Equality in the sense of distributions:

$$R\left(\frac{d}{dt}\right)w = 0 \quad \Leftrightarrow \quad \int_{-\infty}^{+\infty} w(t)^\top \left(R\left(-\frac{d}{dt}\right)^\top f\right)(t) dt = 0$$

for all testing functions f .

In the remainder of this lecture,

$$\mathbf{kernel} \left(R\left(\frac{d}{dt}\right) \right) := \left\{ w \in \mathcal{L}_1^{\text{loc}}(\mathbb{R}, \mathbb{R}^w) \mid R\left(\frac{d}{dt}\right)w = 0 \right. \\ \left. \text{in the sense of distributions} \right\}$$

The state property revisited

$\Sigma = (\mathbb{T}, \mathbb{W}, \mathbb{X}, \mathcal{B}_{\text{full}})$ is a **state system for a LTIDS** if

$$(w_1, x_1), (w_2, x_2) \in \mathcal{B}_{\text{full}} \text{ and } x_1(t) = x_2(t)$$

and x_1, x_2 continuous at t



$$(w_1, x_1) \underset{t}{\wedge} (w_2, x_2) \in \mathcal{B}_{\text{full}}$$

‘State map’ $\rightsquigarrow X \left(\frac{d}{dt} \right)$

Equivalently, $\forall (w_1, x_1), (w_2, x_2) \in \mathcal{B}_{\text{full}}$ that are \mathcal{C}^∞ , and ...

$$(w_1, x_1) \underset{t}{\wedge} (w_2, x_2) \in \mathcal{B}_{\text{full}}^{\text{closure}},$$

where closure denotes the **closure in the \mathcal{C}^∞ -topology.**

From kernel representation to state map

Denote $\text{col}((\sigma_+^i(R)))_{i=1,\dots,L} =: \Sigma_R$.

Theorem: Let $\mathcal{B} = \text{kernel}(R(\frac{d}{dt}))$. Then

$$\begin{aligned} R\left(\frac{d}{dt}\right)w &= 0 \\ \Sigma_R\left(\frac{d}{dt}\right)w &= x \end{aligned}$$

is a state representation of \mathcal{B} with state variable x .

¿How to prove it?

When is $w \in \mathcal{B}$ concatenable with 0 ?

$$\begin{aligned} 0 \underset{0}{\wedge} w \in \mathcal{B} &\iff \int_{-\infty}^{+\infty} (0 \underset{0}{\wedge} w)(t)^\top \left(R\left(-\frac{d}{dt}\right)^\top f\right)(t) dt = 0 \\ &\iff \int_0^{+\infty} w(t)^\top \left(R\left(-\frac{d}{dt}\right)^\top f\right)(t) dt = 0 \end{aligned}$$

for all testing functions f .

When is $w \in \mathcal{B}$ concatenable with 0?

$$\begin{aligned}
 \mathbf{0} \underset{\mathbf{0}}{\wedge} w \in \mathcal{B} &\iff \int_{-\infty}^{+\infty} (\mathbf{0} \underset{\mathbf{0}}{\wedge} w)(t)^\top \left(R\left(-\frac{d}{dt}\right)^\top f\right)(t) dt = 0 \\
 &\iff \int_0^{+\infty} w(t)^\top \left(R\left(-\frac{d}{dt}\right)^\top f\right)(t) dt = 0
 \end{aligned}$$

for all testing functions f .

Integrating repeatedly by parts on f yields:

$$\begin{aligned}
 \sum_{k=1}^{\deg(R)} \sum_{j=k}^{\deg(R)} (-1)^{k-1} \left(\frac{d^{j-k}}{dt^{j-k}} w\right)(0)^\top R_j^\top \left(\frac{d^{k-1}}{dt^{k-1}} f\right)(0) \\
 + \int_0^{+\infty} \left(R\left(\frac{d}{dt}\right) w\right)(t)^\top f(t) dt = 0
 \end{aligned}$$

When is $w \in \mathcal{B}$ concatenable with 0?

$$\begin{aligned}
 \mathbf{0} \underset{\mathbf{0}}{\wedge} w \in \mathcal{B} &\iff \int_{-\infty}^{+\infty} (\mathbf{0} \underset{\mathbf{0}}{\wedge} w)(t)^\top \left(R \left(-\frac{d}{dt}\right)^\top f\right)(t) dt = 0 \\
 &\iff \int_0^{+\infty} w(t)^\top \left(R \left(-\frac{d}{dt}\right)^\top f\right)(t) dt = 0
 \end{aligned}$$

for all testing functions f .

Integrating repeatedly by parts on f yields:

$$\begin{aligned}
 &\sum_{k=1}^{\deg(R)} \sum_{j=k}^{\deg(R)} (-1)^{k-1} \left(\frac{d^{j-k}}{dt^{j-k}} w\right)(0)^\top R_j^\top \left(\frac{d^{k-1}}{dt^{k-1}} f\right)(0) \\
 &\quad + \underbrace{\int_0^{+\infty} \left(R \left(\frac{d}{dt}\right) w\right)(t)^\top f(t) dt}_{=0} = 0
 \end{aligned}$$

The state map

$$\sum_{k=1}^{\deg(R)} \sum_{j=k}^{\deg(R)} (-1)^{k-1} \left(\frac{d^{j-k}}{dt^{j-k}} w \right) (0)^\top R_j^\top \left(\frac{d^{k-1}}{dt^{k-1}} f \right) (0) = 0$$



$$\left[\begin{array}{c} f(0) \\ \left(\frac{d}{dt} f \right) (0) \\ \vdots \\ (-1)^{\deg(R)-1} \left(\frac{d^{\deg(R)-1}}{dt^{\deg(R)-1}} f \right) (0) \end{array} \right]^\top (\Sigma_R \left(\frac{d}{dt} \right) w) (0) = 0$$



$$(\Sigma_R \left(\frac{d}{dt} \right) w) (0) = 0$$

The shift-and-cut state map!

Furthermore...

- ▶ **Algebraic characterization, minimality:** as in discrete-time case
- ▶ **State equations:** also **first order in state** variable and **zeroth order in w .**

**From state map
to state representation**

From kernel to state representation

$$R \in \mathbb{R}^{g \times w}[\xi] \rightsquigarrow \text{state map } X \in \mathbb{R}^{n \times w}[\xi]$$

From kernel to state representation

$$R \in \mathbb{R}^{g \times w}[\xi] \rightsquigarrow \text{state map } X \in \mathbb{R}^{n \times w}[\xi]$$

Find:

- ▶ $E, F \in \mathbb{R}^{(n+g) \times n}$, $G \in \mathbb{R}^{(n+g) \times w}$
- ▶ $T \in \mathbb{R}^{(n+g) \times g}[\xi]$ **with** $\text{rank}(T(\lambda)) = g \forall \lambda \in \mathbb{C}$

satisfying

$$E\xi X(\xi) + FX(\xi) + G = T(\xi)R(\xi)$$

From kernel to state representation

$$R \in \mathbb{R}^{g \times w}[\xi] \rightsquigarrow \text{state map } X \in \mathbb{R}^{n \times w}[\xi]$$

Find:

- ▶ $E, F \in \mathbb{R}^{(n+g) \times n}$, $G \in \mathbb{R}^{(n+g) \times w}$
- ▶ $T \in \mathbb{R}^{(n+g) \times g}[\xi]$ **with** $\text{rank}(T(\lambda)) = g \forall \lambda \in \mathbb{C}$

satisfying

$$E\xi X(\xi) + FX(\xi) + G = T(\xi)R(\xi)$$

Linear equations!

From I/O representation to I/S/O representation

I/O representation

$$R = \begin{bmatrix} P & -Q \end{bmatrix}$$

\rightsquigarrow

state map

$$\begin{bmatrix} X_y & X_u \end{bmatrix}$$

Find:

- ▶ $A \in \mathbb{R}^{n \times n}$, $B \in \mathbb{R}^{n \times m}$, $C \in \mathbb{R}^{p \times p}$, $D \in \mathbb{R}^{p \times m}$
- ▶ $T \in \mathbb{R}^{(n+p) \times p}[\xi]$ **with** $\text{rank}(T(\lambda)) = g \forall \lambda \in \mathbb{C}$

satisfying

$$\begin{bmatrix} \xi X_y(\xi) & \xi X_u(\xi) \\ I_p & 0 \end{bmatrix} = \begin{bmatrix} A & B \\ C & D \end{bmatrix} \begin{bmatrix} X_y(\xi) & X_u(\xi) \\ 0 & I_m \end{bmatrix} + T(\xi)R(\xi)$$

Example

State map
+
system equations



state-space
equations

Example

State map
+
system equations



**state-space
equations**

Example

State map
+
system equations



state-space
equations

$$\left(\frac{d^2}{dt^2} + 2\frac{d}{dt} + 3\right)y = \left(\frac{d}{dt} + 3\right)u$$

$$\left[\xi^2 + 2\xi + 3 \quad \vdots \quad -\xi - 3 \right]$$

Example

State map
+
system equations

\rightsquigarrow

state-space
equations

$$\left(\frac{d^2}{dt^2} + 2\frac{d}{dt} + 3\right)y = \left(\frac{d}{dt} + 3\right)u$$

$$\left[\xi^2 + 2\xi + 3 \quad \vdots \quad -\xi - 3 \right]$$

Take $X(\xi) = \begin{bmatrix} 1 & 0 \\ \xi + 2 & -1 \end{bmatrix}$ ('reverse shift-and-cut'). Then

$$A = \begin{bmatrix} -2 & 1 \\ -3 & 0 \end{bmatrix} \quad B = \begin{bmatrix} -1 \\ -3 \end{bmatrix}$$
$$C = \begin{bmatrix} 1 & 0 \end{bmatrix} \quad D = \begin{bmatrix} 0 \end{bmatrix}$$

'observer canonical form'

Example

State map
+
system equations

\rightsquigarrow

state-space
equations

$$\left(\frac{d^2}{dt^2} + 2\frac{d}{dt} + 3\right)y = \left(\frac{d}{dt} + 3\right)u$$

$$\left[\xi^2 + 2\xi + 3 \quad \vdots \quad -\xi - 3 \right]$$

Take $X(\xi) = \begin{bmatrix} 1 & 0 \\ \xi & -1 \end{bmatrix}$. **Then**

$$A = \begin{bmatrix} 0 & 1 \\ -3 & -2 \end{bmatrix} \quad B = \begin{bmatrix} 1 \\ 1 \end{bmatrix}$$
$$C = \begin{bmatrix} 1 & 0 \end{bmatrix} \quad D = \begin{bmatrix} 0 \end{bmatrix}$$

‘observable canonical form’

- ▶ **The state is constructed!**
- ▶ **State property: concatenability with 0 is key.**
- ▶ **State maps: from manifest variable to state variable.**
- ▶ **State maps \rightsquigarrow state-space equations.**
- ▶ **Algorithms based on standard polynomial algebra computations.**

Recapitulation

Summary

- ▶ **First principles models invariably contain latent variables.**

Summary

- ▶ **First principles models invariably contain latent variables.**
- ▶ **For LTIDSs latent variables can be eliminated.**

Summary

- ▶ **First principles models invariably contain latent variables.**
- ▶ **For LTIDSs latent variables can be eliminated.**
- ▶ **The three main theorems for LTIDSs: the $1 \leftrightarrow 1$ relation with submodules, the equivalence of controllability and image representations, and the elimination theorem generalize, *mutatis mutandis*, to PDEs.**

Summary

- ▶ **First principles models invariably contain latent variables.**
- ▶ **For LTIDSs latent variables can be eliminated.**
- ▶ **The three main theorems for LTIDSs: the $1 \leftrightarrow 1$ relation with submodules, the equivalence of controllability and image representations, and the elimination theorem generalize, *mutatis mutandis*, to PDEs.**
- ▶ **State property \Leftrightarrow concatenability, assuming same value of the state.**

Summary

- ▶ **First principles models invariably contain latent variables.**
- ▶ **For LTIDSs latent variables can be eliminated.**
- ▶ **The three main theorems for LTIDSs: the $1 \leftrightarrow 1$ relation with submodules, the equivalence of controllability and image representations, and the elimination theorem generalize, *mutatis mutandis*, to PDEs.**
- ▶ **State property \Leftrightarrow concatenability, assuming same value of the state.**
- ▶ **State equations: first order in x , zeroth-order in w .**

Summary

- ▶ **First principles models invariably contain latent variables.**
- ▶ **For LTIDSs latent variables can be eliminated.**
- ▶ **The three main theorems for LTIDSs: the $1 \leftrightarrow 1$ relation with submodules, the equivalence of controllability and image representations, and the elimination theorem generalize, *mutatis mutandis*, to PDEs.**
- ▶ **State property \Leftrightarrow concatenability, assuming same value of the state.**
- ▶ **State equations: first order in x , zeroth-order in w .**
- ▶ **Construction of state using shift-and-cut map.**

End of Lecture III