

A NEW INNER 360° MEASUREMENT PROCEDURE FOR THREE DIMENSIONAL GEOMETRICAL MEASUREMENTS

A. Göpfert, M. Rückwardt, M. Rosenberger, M. Correns, M. Schellhorn, G. Linß

Ilmenau University of Technology, Faculty of Mechanical Engineering, Department Quality Assurance, Gustav-Kirchhoff-Platz 2, 98693 Ilmenau, Germany

ABSTRACT

Inspection and measurement of geometrical quantities is a wide complex field. An example is three dimensional measurement of the groove of spectacle frames. Every groove is an undercut in material of the spectacle frame and therefore the direct optical path of coordinate measuring machines is blocked. A known measurement procedure is a combination of optical measurement and a plane mirror for beam deflection. Disadvantages of this method are a limited field of view and also a long testing time. An improvement of the solution is a cone mirror in combination with a high resolution camera-system. With this kind of beam deflection a simultaneous measurement of 360° is possible. The angle of the frame in polar coordinates is given by special image detection algorithms and backtracking of the form of the cone mirror. The distance of the associated measuring point can be detected by an autofocus for every detected point in the image. This combination of camera-system, beam deflection and software algorithms is advancement in speeding up the optical measurement of spectacle frames.

Index Terms – three dimensional, eyeglass frame, focus ride, optical measurement, cone mirror

1. INTRODUCTION - DESCRIPTION OF THE MEASURING PROBLEM

Difficulties of measuring objects like eyeglass frames are miscellaneous. For the most part of measuring challenges there is a detailed drawing or a target dimension of the device under test. In case of eyeglass frames, drawings are not free accessible and high manufacturing tolerances are given [4]. Even an eyeglass frame has no fixed rules in form, design, material or dimensions. Thereby a lot of other problems like handling, fixing or even a mathematical model are not ordinary. These are the general disadvantages. There are even disadvantages because each tactile measurement method depends on contact and geometrical properties of the calliper and elected parameters. These are reasons of the Department of Quality Assurance from the Faculty of Mechanical Engineering of the Technical University of Ilmenau promoted by the Federal Ministry of Economics and

Technology within the framework of the InnoNet program to research for a new procedure for detecting deviations behind an undercut.

An example about measuring an eyeglass frame is shown in figure 1. There you can see the cone mirror and the frame. The cone mirror is in the center of the device under test, otherwise you cannot see the undercut of the device. Also there you can see 3 arrows, which show exemplary the way of the optical imaging. How can be seen, from every direction (360 degree) a point of the device is pictured.

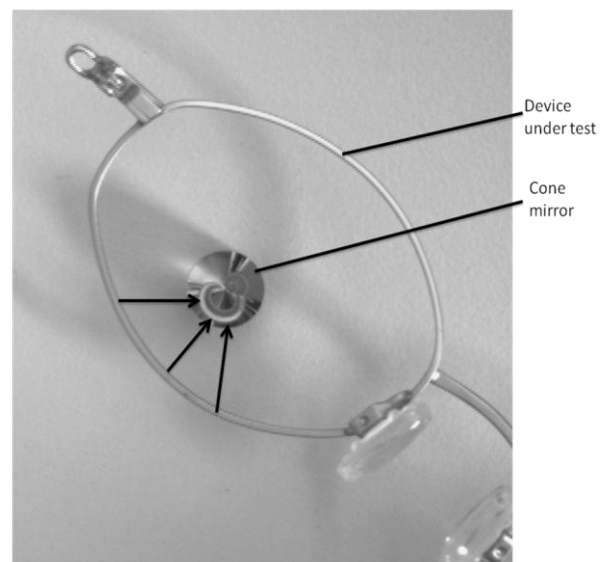

Figure 1: clear view of device under test and cone mirror in the middle

The groove is necessary to fix the special produced eyeglass lens. For lens edging even the ground of the three dimensional ground of the groove is needed. Also you can see the main problem. The frame can be anywhere in the area of the measuring machine and is variable in all three dimensions.

2. BASIC PRINCIPLE

The challenge of two dimensional image processing is to solve three dimensional measurement problems. To get the third dimension, there are a lot of solutions like light-section or stereoscopy. Another principle is to get the focus of a point in image. The focus point is addicted to the optical system with parameters like

focal distance and aperture [1]. By the realization of this measurement procedure, a focus ride by the optical system is the base. By the focus ride several images associated to several positions on Z-Axis are grabbed. By analyzing the noise, variance and contrast of several areas of interests in every image, the focus point will be calculated and a measuring point will be received.

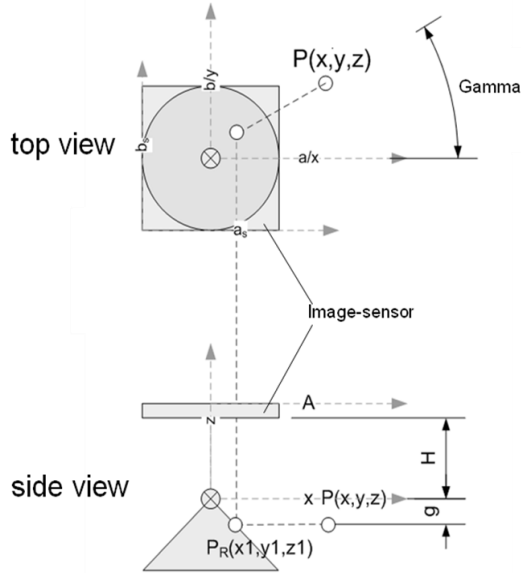

Figure 2: image sensor and cone mirror with measuring point P in top and side view

As can be seen in Figure 2 the image sensor is rectangular to the z-axis. Even there are two other coordinate-systems - a world-coordinate system with x, y and z and a local-coordinate-system, which is beginning in one corner of the image sensor. Zero point on scale of a-axis and x-axis are the same like b-axis and y-axis. The zero point on scale of z-axis is the cone of the cone mirror.

Also to get the world coordinates of measuring point P there are needed the pixel coordinates, the z-coordinate of the image sensor and the position of cone mirror and even a steady focal distance.

The pixel coordinates relative to position of the top of cone mirror will give the z- coordinate of point P and the angle gamma. These parameters are only given by the optical path. Together with the height z and focal distance there is the result of the coordinates x and y for the measuring point.

To get the focal distance of the system a calibration is needed. Problem in doing are bad conditions to focus to the top of cone mirror. Here a focus drive to another object is needed or better to the lower boarder of cone mirror is an alternative.

To get focus position of the measuring point itself is equally complicated. To select the focus of a point or area in picture is solved by different focus-criteria. Three criteria were tested. The criteria are based on contrast, scatter and noise. Due to the fact that a

spectacle frame can be out of every material. The material can be simple metal up to titanium, carbon or plastics. At metal and soon characteristics of reflection are even ideal for a focus ride. Here can be found a very good reflection from the groove and soon a detection of measuring point and focus is able with all three criteria.

In Case of plastics, there can be a matt surface as far as a glossy surface or transparent plastics. In these cases special illumination and specified criteria for focus and measuring point detection is needed. An illumination with a ring-light was the best tested solution in combination with the criteria of scatter. Here the standard deviation at a lab setup was in the area of a few micrometers.

How to get this coordinates in detail will be described in next passage.

3. MATHEMATICAL SOLUTION

In this passage the detailed calculation of the coordinates of measuring point P will be described. How be described several inputs are needed to calculate the coordinates of a measuring point P.

The complete formula is shown in Figure 3. At the beginning it should be described how to calculate the z-coordinate of P. The z-coordinate is the negative of the variable g. It is the negative, because the z-coordinate is the cone of the cone mirror. The variable g can be calculated over theorem of Pythagoras with the values of the measuring point on the image sensor.

$$g = \sqrt{\left(x - \frac{a}{2}\right)^2 + \left(y - \frac{b}{2}\right)^2}$$

$$\begin{bmatrix} X \\ Y \\ Z \end{bmatrix} = \begin{bmatrix} a + (f - H - g) * \cos(\gamma) \\ b + (f - H - g) * \sin(\gamma) \\ -g \end{bmatrix}$$

Figure 3: formulas to calculate the values x, y, and z for measuring point P

How can be seen the x- and y-coordinates are not as easy as the z-coordinate. There was used a number of seven principal axis transformations. These are translational and rotational displacements. In short form, the x- and y-coordinates of the measuring point are the sum of the given value of image sensor plus the cosine alternatively sine of the angle gamma multiplied with the difference of focal distance minus g and the H. This is the point where three dimensional coordinates can be calculated from a two-dimensional image sensor. The variable g was explained. The variable H is the height of the image sensor to the top of the cone mirror.

With this simple transformation of coordinates, a cone mirror and a focal ride, three dimensional coordinates can be measured.

4. PRACTICAL TEST

To get a quantitative result of the measurement procedure, different eyeglass frames were measured. An example is shown in Figure 4. This example is predestinated, because of three well-defined colors of the material. In the centre of the eyeglass frame is a cone mirror (diameter 15mm) which shows these three colors. As can be seen the upper side is red, the lower side is yellow and the groove to detect is black.

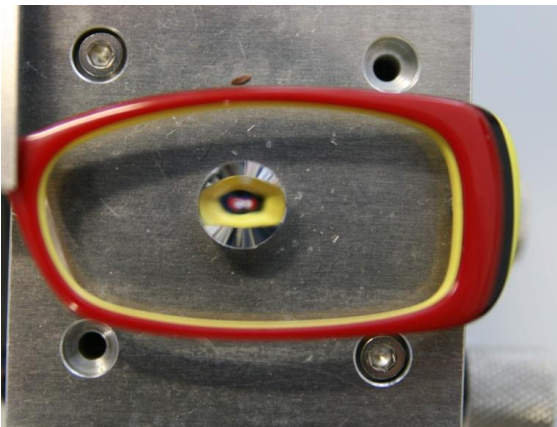

Figure 4: cone mirror with device under test, which consists of three good well-defined colors

Also as can be seen on cone mirror the optical imaging is yellow on the outside section of cone mirror whereas the inner section is red, which shows the upper side. Here the main problem gets visible. Although the red and yellow area of the eyeglass frame is equal in dimensions of x and y, the optical imaging is very different. This is not a phenomenon but rather the result of different heights alternatively z-coordinates.

How closer the eyeglass frame gets to the top of the cone mirror, how smaller the optical imaging is. The results are problems in resolution and soon groove detection. How explained the x- and y-coordinates will be get by focus ride, but in Figure 4 all points of the image are in focus. To solve this problem another optical system has to be chosen or the length of the focus ride has to be elongate.

As can be seen in Figure 5 the detection of many points is represented. Attention has to be attending to the upper and lower side, where no points were found in image. A reason could be the focus ride. If the measuring object would be out of the range of focus ride, no measuring points would be found. Also attention has to be attracted to distance of measuring point to the circle. It seems to be even for every point, which means, that the height of the measuring points seems to be even.



Figure 5: cone mirror with device under test

At the end the bright lines in the measuring figure should be explained. The bright outline is the border of the lower side. The bright line on the inside is the border of the upper side. The bright line between is the wanted groove of the eyeglass.

The result of axis transformation is shown in Figure 6. On top of Figure 6 the measuring points are shown in two dimensions. These are the calculated points of the x-y-plane. It seems like Figure 5, but only at the first sight. Down in Figure 6 there are the calculated measuring points in Cartesian coordinate system.

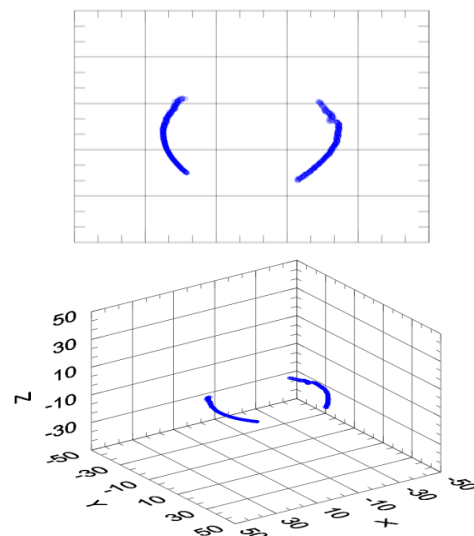

Figure 6: calculated coordinates of the measuring device – up: coordinates (2D) of the points in picture – down calculate: coordinates (3D) of the points

5. CONCLUSION

In this paper the challenge of a special measuring problem would be described. The measuring problem contains the three dimensional measuring of the groove of eyeglass frames. Eyeglass frames have no rules in form, design and dimension. The shown solution is by image processing with an optical and mechanical system in combination with a cone mirror.

By the shown combination and the image processing technique of a focus ride the three-dimensional points can be calculated.

At last there are problems to be solved. Because of the small area on top of the cone mirror, the solution mostly is too low. A minimum of solution is needed, but because of the minimum dimensions of eyeglass frames it is not able to measure all models of eyeglass frames with a larger cone mirror. Also the z-dimensions are mostly higher than the measurement range with this small cone mirror, so a readjustment is needed.

6. REFERENCES

[1] B. Jähne, Practical handbook on image processing for scientific and technical applications, CRC Press, 2004

[2] B. Jähne, Digitale Bildverarbeitung, Springer, Berlin, 2002

[3] G. Linß, Qualitätsmanagement für Ingenieure, Fachbuchverlag Leipzig im Carl Hanser Verlag, München, Wien, 2002

[4] M. Wettig, Untersuchungen zur taktilen automatischen Messung mit taktilen Koordinatenmeßgeräten, Ilmenau, 2009

[5] N. Ebinger, Untersuchungen zur Prüfplanung, Optimierung und Wirtschaftlichkeit von Messungen mit optisch-taktilen Koordinatenmessgeräten, Ilmenau, 2009