

Network Security

Chapter 10

Integrating Security Services into Communication Architectures

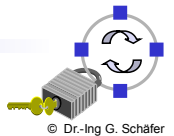

Motivation: What to do where?

- Analogous to the methodology of security analysis, there are *two dimensions* guiding the integration of security services into communications architectures:

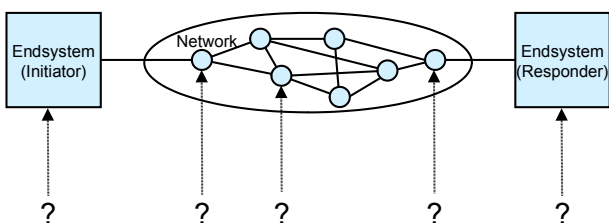

Dimension 1:

Which security service should be realized in which node?

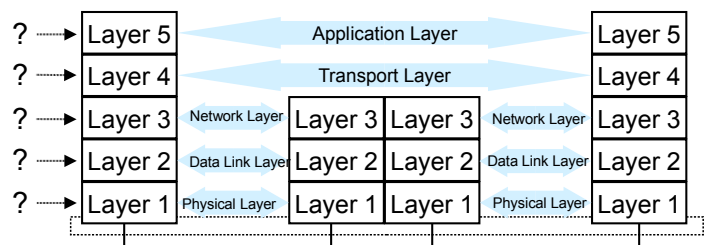

Dimension 2:

Which security service should be realized in which layer?

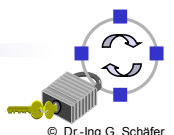

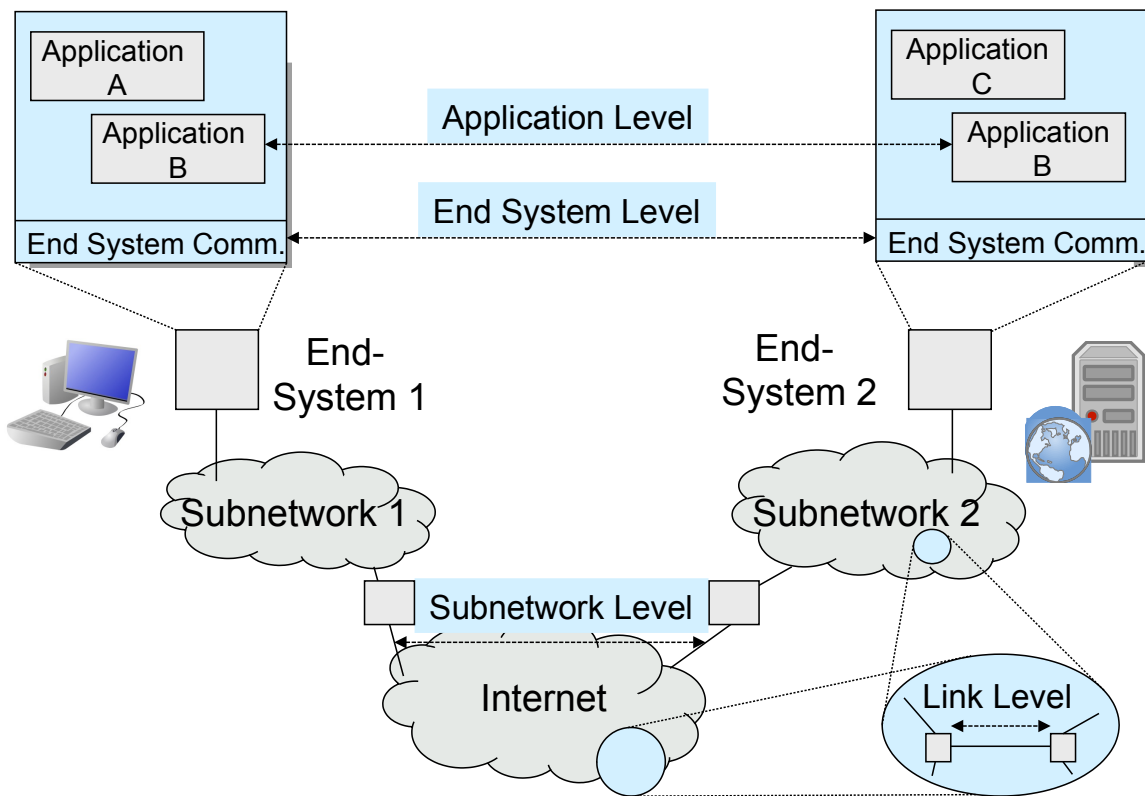

- ❑ **Application:**
 - ❑ A piece of software that accomplishes some specific task, e.g. electronic email, web service, word processing, data storage, etc.
- ❑ **End System:**
 - ❑ One piece of equipment, anywhere in the range from personal computer to server to mainframe computer
 - ❑ For security purposes one end system usually has one policy authority
- ❑ **Subnetwork:**
 - ❑ A collection of communication facilities being under the control of one administrative organization, e.g. a LAN, campus network, WAN, etc.
 - ❑ For security purposes one subnetwork usually has one policy authority
- ❑ **Internet:**
 - ❑ A collection of inter-connected subnetworks
 - ❑ In general, the subnets connected in an inter-network have different policy authorities

- ❑ There are four levels at which distinct requirements for security protocol elements arise:
 - ❑ *Application level*:
 - Security protocol elements that are application dependent
 - ❑ *End system level*:
 - Provision of protection on an end system to end system basis
 - ❑ *Subnetwork level*:
 - Provision of protection over a subnetwork or an inter-network which is considered less secure than other parts of the network environment
 - ❑ *Link level*:
 - Provision of protection internal to a subnetwork, e.g. over a link which is considered less trusted than other parts of the subnetwork environment

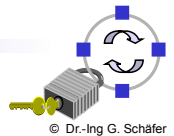

Relationships Between Layers & Requirements Levels

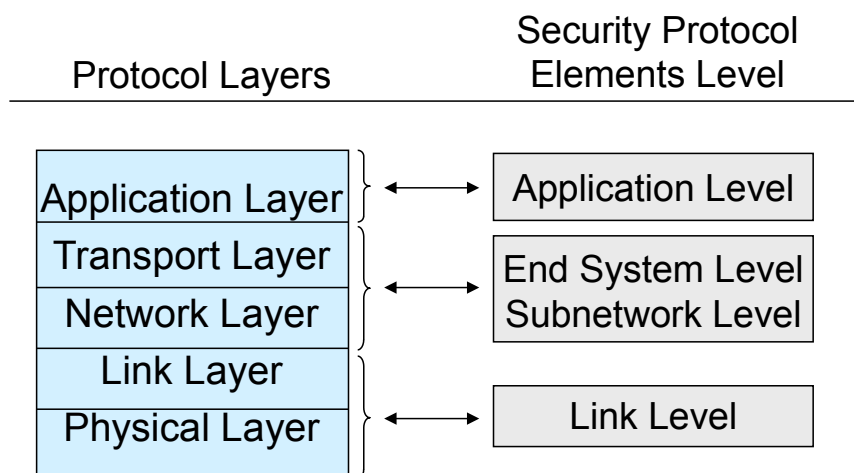

- ❑ The relations between protocol layers and the protocol element security requirements levels are not one-to-one:
 - ❑ Security mechanisms for fulfilling both the end system and the subnetwork level requirements can be either realized in the transport and / or the network layer
 - ❑ Link level requirements can be met by integrating security mechanisms or using “special functions” of the either the link layer and / or the physical layer

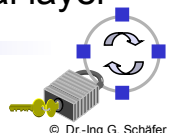

- ❑ **Traffic mixing:**
 - ❑ As a result of multiplexing, there is greater tendencies at lower levels to have data items from different source/destination-users and / or applications mixed in one data stream
 - ❑ A security service realized at one layer / level will treat the traffic of that layer / level in an equal manner, resulting in inadequate control over security mechanisms for users and applications
 - ❑ If a security policy demands for a more differentiated treatment, it should be better realized at a higher level
- ❑ **Route knowledge:**
 - ❑ At lower levels, there tends to be more knowledge about the security characteristics of different routes and links
 - ❑ In environments, where such characteristics vary significantly, placing security at lower levels can have effectiveness and efficiency benefits
 - ❑ Appropriate security services can be selected on a subnetwork or link basis eliminating cost for security, where protection is unnecessary

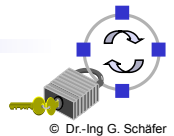

- ❑ **Number of protection points:**
 - ❑ Placing security at the application level requires security to be implemented in every sensitive application and every end system
 - ❑ Placing security at the link level requires security to be implemented at the end of every network link which is considered to be less trusted
 - ❑ Placing security in the middle of the architecture will tend to require security features to be installed at fewer points
- ❑ **Protocol header protection:**
 - ❑ Security protection at higher levels can not protect protocol headers of lower protocol layers
 - ❑ The networking infrastructure might need to be protected as well
- ❑ **Source / sink binding:**
 - ❑ Security services like data origin authentication and non-repudiation depend upon association of data with its source or sink
 - ❑ This is most efficiently achieved at higher levels, especially the application level



- ❑ *Application level:*
 - ❑ This level might be the only appropriate level, for example because:
 - A security service is application specific, e.g. access control for a networked file store
 - A security service needs to traverse application gateways, e.g. integrity and / or confidentiality of electronic mail
 - Semantics of data is important, e.g. for non-repudiation services
 - It is beyond the reach of a user / application programmer to integrate security at a lower level
- ❑ *End system level:*
 - ❑ This level is appropriate when end systems are assumed to be trusted and the communication network is assumed to be untrusted
 - ❑ Further advantages of end system level security:
 - Security services are transparent to applications
 - The management of security services can be more easily given in the hands of one system administrator

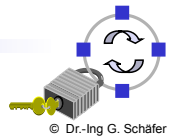

- ❑ *Subnetwork level:*
 - ❑ Even if security implemented on this level might be implemented in the same protocol layer like for the end system level, these should not be mixed up:
 - With security implemented on the subnetwork level, usually the same protection is realized for all end systems of that subnetwork
 - ❑ It is very common, that a subnetwork close to an end system is considered equally trusted, as there are on the same premises and administered by the same authorities
 - ❑ In most situations there are far less subnetwork gateways to be secured than there are end systems
- ❑ *Link level:*
 - ❑ If there are relatively few untrusted links, it might be sufficient and as well easier and cheaper to protect the network on the link level
 - ❑ Furthermore the link level allows to make use of specific protection techniques, like spread spectrum or frequency hopping techniques
 - ❑ Traffic flow confidentially usually demands for link level protection

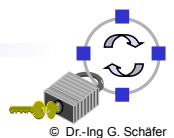

- ❑ Some network security services involve direct interaction with a human user, the most important one being authentication
- ❑ Such interactions do not cleanly fit into any of the architectural options presented so far, as the user is external to the communication facilities
- ❑ Communications supporting authentication can be realized in one of the following manners:
 - ❑ *Locally:*
 - The human user authenticates to the local end system
 - The end system authenticates itself to the remote end system and advises the user identity
 - The remote system has to trust the local end system
 - ❑ *Involving protocol elements at the application layer:*
 - The user passes some authentication information to the local system which is securely relayed to the remote system
 - ❑ *Combining the above means:*
 - Example: Kerberos

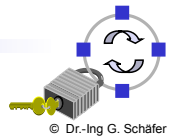

- ❑ Benefits of integrating security services into lower network layers:
 - ❑ *Security:*
 - The network itself also needs to be protected
 - Security mechanisms realised in the network elements (esp. in hardware) are often harder to attack for network users
 - ❑ *Application Independence:*
 - Basic network security services need not be integrated into every single application
 - ❑ *Quality of Service (QoS):*
 - QoS preserving scheduling of the communication subsystem can also schedule encryption of co-existing data streams
 - Example: simultaneous voice call and FTP transfer
 - ❑ *Efficiency:*
 - Hardware support for computationally intensive encryption / decryption can be easier integrated into protocol processing



- ❑ Integration into end systems:
 - ❑ Can be done generally either on the application or end system level
 - ❑ In some special cases also a link level protection might be appropriate, e.g. when using a modem to connect to a dedicated device
- ❑ Integration into intermediate systems
 - ❑ Can be done on all four levels:
 - Application / “end system” level: for securing management interfaces of intermediate nodes, not for securing user data traffic
 - Subnetwork / link level: for securing user data traffic
- ❑ Depending on the security objectives an integration in both end systems and intermediate systems might be appropriate

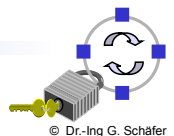

Example: Authentication Relations in Inter-Networks

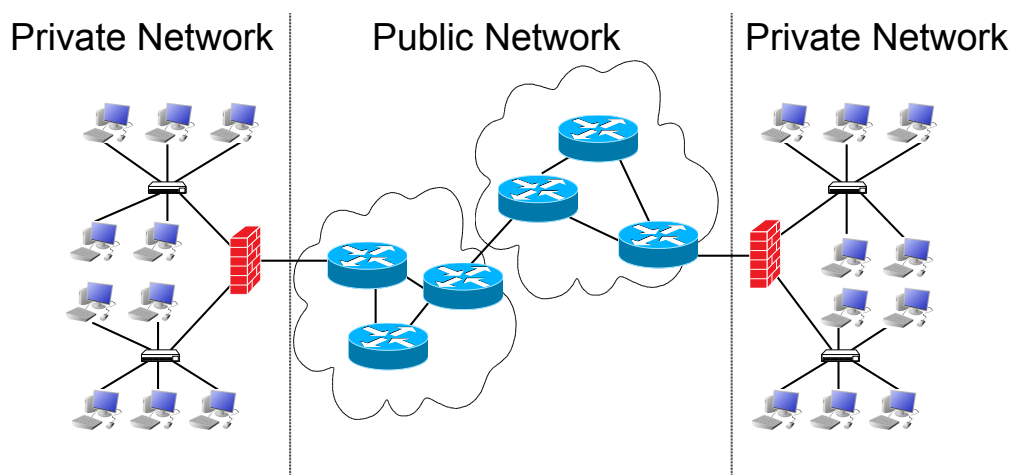

Authentication Relation	Application for securing
Endsystem ↔ Endsystem	User Channels
Endsystem ↔ Intermediate System	Management Interfaces, Accounting
Intermediate ↔ Intermediate System	Network Operation: Signaling Routing, Accounting, ...



- ❑ Integration of security services into communications architectures is guided by two main questions:
 - ❑ Which security service into which node?
 - ❑ Which security service into which layer?
- ❑ These design choices can also be guided by looking at a pragmatic model of networked computing which distinguishes four different levels on which security services may be realized:
 - ❑ Application / end system / subnetwork / link level
- ❑ As there are various reasons for and against each option, there is no single solution to this design problem
- ❑ In this course we will, therefore, study some examples of security services integration into network architectures in order to better understand the implications of the design choices made