

CONTROL OF SENSORY PROCESSING - A HYPOTHESIS ON AND SIMULATION
OF THE ARCHITECTURE OF AN ELEMENTARY CORTICAL PROCESSOR

E. Koerner⁺, M. Gross⁺, A. Richter⁺ and H. Shimizu⁺⁺

1. The Problem

The cortex with its high flexibility of processing consists of a regular columnar structure, where the minicolumn as a firmware structure of about 110 Neurons can be considered to be the elementary processing element. There is an interesting model concerning this columnar structure based on localized groups of homogeneous formal elements with probabilistic features (2). However, those minicolumns are not a pool of randomly connected neurons but have a characteristic layered structure and are composed of several distinct neuron types with specific processing characteristics. There is evidence, that these layers cannot be explained by a coding hierarchy (3) and only some part of that may be due to mapping processes between different phase spaces (4). What then is it for? In putting this problem into the framework of a definitive job in early visual processing, we submitted evidence that this layered structure represents a kind of flexible control hierarchy which enables the manipulation of the thalamic interface such that the highly parallel sensory inputs to the cortex can be picked up as a sequence of lower dimensional parallel bytes, which are reassembled towards a completely parallel representation, in a way to ensure a rapid and smooth convergence of the interpretation process (1). We argue, that such a more complex structure of a single node in a network may be crucial for getting more flexibility in the network's behavior.

2. The model

In Brain computing interpretation means the formation of an activity distribution in the cortex which sufficiently matches the activity distribution of sensory inputs at the interface to the cortex. For a couple of reasons (1), the thalamus can be regarded to be such an interface.

⁺ The Ilmenau Institute of Technology, Ilmenau, 6300, GDR

⁺⁺ Tokyo University, Pharm. Faculty, Dep. Biophysics, Tokyo 113,
Hongo 3-chome, Japan

Results in psychophysics suggest, that the retinal input does never enter completely in parallel the pathways to the cortex but that there is an internal scanning process even between the fixation saccades of the eye (6). (For more details see (1).)

Our model framework submits a hypothesis in which way this internal scanning could be controlled by cortical feedback as to get a random access grouping such that the parallel visual byte at the interface is decomposed into a sequence of smaller dimensional bytes representing definite known parts of the image which are subsequently reassembled via synchronization towards complete and consistent interpretation of the input. This temporary partial sequencing of the parallel input may prevent a combinatorial explosion of the interpretation process since the cortical control guides the associative search towards the most probable decision.

2.1. The model thalamic interface

Sensory inputs enter the cortex via thalamic relay neurons (Th) passing the reticular formation, the neurons of which (Re) form a mutually locally inhibiting network. There is a recurrent feedback from pyramidal neurons of layer 6 (Py6) to the Re and Th by the entrained cortical activity. A local inhibition (Li) produces a raising inhibitory level with entrained cortical activity that tends to close all channels except those which get support by cortical feedback, the Re of which carving this channel out of the inhibitory block by inhibiting the respective Li.

$$Th(i, j, k) = Schw \left\{ \begin{aligned} &(1 + W_{ThI} * I(i, j, k-1) + W_{ThP6} * Py6(i, j, k-1) \\ &+ lam11 * Th(i, j, k-1)) / (1 + w4 * Li(i, j, k-1)) - 1 \end{aligned} \right\}$$

$$Re(i, j, k) = Schw \left\{ \begin{aligned} &(1 + W_{ReP6} * Py6(i, j, k-1) + W_{ReTh} * Th(i, j, k-1) \\ &+ lam12 * Re(i, j, k-1)) / (1 + a03 * \sum_{u, v \in sur2} Re(u, v, k-1)) - 1 \end{aligned} \right\}$$

$$Li(i, j, k) = Schw \left\{ \begin{aligned} &(1 + a04 * \sum_{u, v \in sur1} Py6(u, v, k-1) + a05 * \sum_{u, v \in sur3} Th(u, v, k-1) \\ &+ a06 * \sum_{u, v \in sur3} I(u, v, k-1) + lam13 * Li(i, j, k-1) / \\ &(1 + W_{LiRe} * Re(i, j, k-1)) - 1 \end{aligned} \right\}$$

$$\text{where Schw}(a) = \begin{cases} (0 & \text{if } a < 0) \\ (a & \text{if } a \in (0, 20)) \\ (20 & \text{if } a > 20) \end{cases}$$

Hence, a limited part of the parallel input is only to be decided on by the cortex. Then these related channels are purged from the input by a cortical erase command and the next strongest set of inputs can enter the pathway to the cortex.

2.2. The model macrocolumn

In which way is the cortico-thalamic control organized to start this decomposition of the parallel input into a sequence of flashing groups of input channels which contain the information most appropriate for a rapid convergence of the interpretation and, second, how to link these subsets of the input image back to synchronism while creating a semantic structure?

Based on the principle of modular organization of the neocortex including the available sound knowledge on the cortical hardware we propose a model of a neocortical minicolumn as an elementary cortical processor, which can support such a content dependent selforganization within a large scale system composed of such elements /1/, /2/. According to our computational hypothesis on early vision the architecture of the 6-layered neocortical columns fits best into a framework of a dynamic control hierarchy for pattern formation. A model minicolumn consists of

i) a syntactic detector which limits the visual byte (parallel visual input) to a drastically smaller dimensional byte containing only the input channels with the highest local and global syntactic complexity, (R0)

ii) a semantic classifier which modifies this grouping towards the largest possible semantic structure and generates a repetitive sequence of a limited number of such puls-like flashing "variable bytes" (sets of input channels representing a semantic concept at the retinal image) (R1) and

iii) a semantic linker, (R2) which guides this time sequence of variable bytes back to synchronism by means of consensus formation and its feedforward to the semantic classification.

R0 consists of an associative memory (Py6) resembling the pyramidal neurons of layer 6 which is continually communicating with an adaptive filter made up by a two layered structure of excitatory spiny stellate cells (SS0) and inhibitory nonspiny stellate of layer 4 (NSS0).

$$Py6_1(i, j, k) = Schw \left\{ \begin{aligned} &lam61 * Py6(i, j, k-1) + W_P6Th * Th(i, j, k-1) \\ &+ w_P6P6 * sumPy6(i, j, k-1) + W_P6Ss * sumSs(i, j, k-1) \\ &+ W_P6P3 * sumPy3(i, j, k-1) - m61 * mgl6ob6 \end{aligned} \right\}$$

$$Py6(i, j, k) = Schw \left\{ Py6_1(i, j, k) - SBc6(i, j, k-1) \right\}$$

$$SBC6(i, j, k) = SchwBa \left\{ WBa60 * Py6(i, j, k-1) + WBa61 * SBC6(i, j, k-1) \right\}$$

$$Ss0(i, j, k) = Schw \left\{ \begin{aligned} &lam41 * Ss1(i, j, k-1) + W_SsTh * Th(i, j, k-1) \\ &+ W_SsP6 * sumPy6(i, j, k-1) \\ &- m41 * mgl6ob4 - NSs(i, j, k) \end{aligned} \right\}$$

$$NSs0(i, j, k) = Schw \left\{ \begin{aligned} &va / \\ & \sum_{u, v=-r}^r (1+b43 * NSs(i+u, j+v, k-1) + v45 * Ss(i, j, k-2) - 1) \end{aligned} \right\}$$

with

$$sum_Source(i, j, k-1) = Schw \left\{ \sum_{u, v} W_Target_Source(i, j, u, v) * Source(u, v, k-1) \right\}$$

$$SchwBa(a) = \begin{cases} (0 & \text{if } a < Schw_Ba) \\ (a & \text{if } a \leq 20) \\ (20 & \text{if } a > 20) \end{cases}$$

This first decision on the input is a local one, since Py6 is only connected to the next nearest neighbour minicolumn. SSO feeds this decision to R1, an autoassociative memory of the HASP-type (7), while Py6 gives the feedback to Th, Re trying to support and keep the input active. The range of autoassociative mapping at R1 exceeds all next nearest neighbour macrocolumns, furthermore by sending and receiving the selected decision to and from all other macrocolumns (LCC), the local decision is turned towards a global one.

$$Py3(i, j, k) = Schw \left\{ \begin{aligned} &lam31 * Py3(i, j, k-1) + W_P3Ss * Ss(i, j, k-1) \\ &+ W_P3Th * Th(i, j, k-1) - a31 * sumPy3(i, j, k-1) \\ &- m31 * mgl6ob3 \end{aligned} \right\}$$

$$sumPy3(i, j, k-1) = Schw \left\{ \sum_{u, v} WP3P3(i, j, u, v) * Py3(u, v, k-1) \right\}$$

R2 was not included into this model minicolumn because of its tremendous complexity and the shortage of available working memory. To emulate in a primitive but instructive way the R2 we simply added a system Py2

$$Py2(i, j, k) = Schw\{ lam21 * Py2(i, j, k-1) + lam22 * Schw\{ Py3(i, j, k-1) - MinPy3\} \}$$

which keeps strong R1 decisions and gives a feedforward to R1, R0 to support the synchronization of noncompetitive parts of the image. The thalamic inhibition Li strongly depends on "cortical" activity. Since while starting the process only R0 is active, any Py6 has the chance to control its thalamic input channel via Re. With entraining R1, R2 then Py6 activity is not sufficient to suppress LI locally via Re except it gets additional support by R1, R2 feedback. An inhibitory neuron type sbc6 (small basket cell of layer 6) acts with its nonlinear switching characteristics to delete the support for those thalamic channels which belong to a stable entrained (and therefore recognized) pattern. Any subsystem of the module has its normalization procedure (mglob 3, 4, 6) to keep the full dynamic range of neural activity ready for processing.

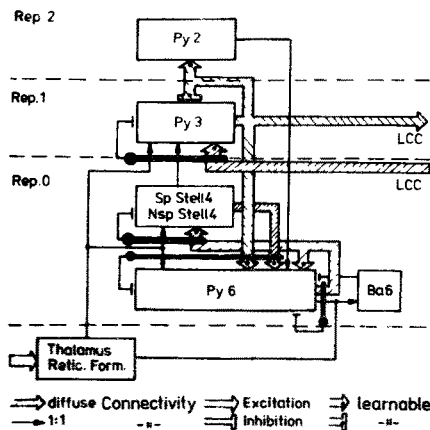

Fig.1
 Schematic structure of an elementary cortical processor modul; most important subsystems and signal flow paths are marked (see text)

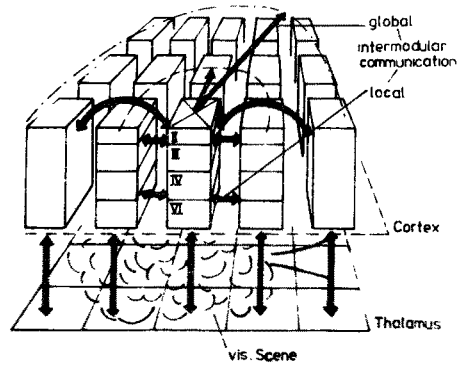

Fig.2
 5 x 5 macrocolumnar array each of which consisting of 3 x 3 minicolumns. The intramodular connectivity is heavy between all subsystems vertically, the intermodular connectivity is horizontally local in layer 6 and global in 3.

2.3. The model columnar array

Limited by the memoryspace of the PC used for simulation, only 3 x 3 matrix dimensions for the subsystems of minicolumns in each macrocolumn was accepted. The array is consisted of 5 x 5 macrocolumns each of which is autonomous to some degree but can slave other ones or can be slaved via the connectivity LCC in R1. A minicolumn in this array corresponds to a set of elementary feature detectors (not pixels!) (cf. Fig. 2).

3. Simulation results

In the case of a single column the emphasis in simulation was given to the dynamics of the decomposition parallel to sequence and the variable byte formation. Fig. 3 shows the sequential ranking of 3 texture elements according to its syntactic complexity (lower part of the fig.) while another texture cannot enter the input to the cortex (Thal 42). Related R0, R1 activity is shown (middle part) and the upper traces show the Li-control for both a selected channel and a nonrelevant channel.

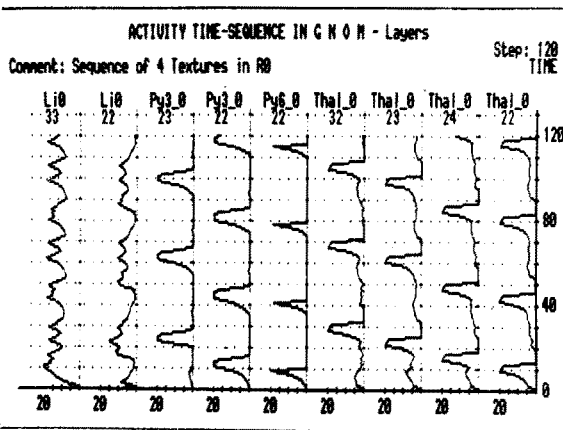

Fig. 3

Turning a parallel thalamic scene into a sequence of known texture elements by R0 control in a macrocolumn. Any symbolic texture element is a pool of 3 line detectors, coded in the subsequent process of learning.

In the case of the columnar array, a scene covers the 5 x 5 matrix, to be seen in Fig. 4. Two of the modular subsystems of the array, the thalamic interface and R1, are shown 5 time steps after presentation of a scene composed of 6 texture elements. The known ones are instantly synchronized to a parallel recall, the unknown part having been ranked in the sequence according to the completeness of texture groups.

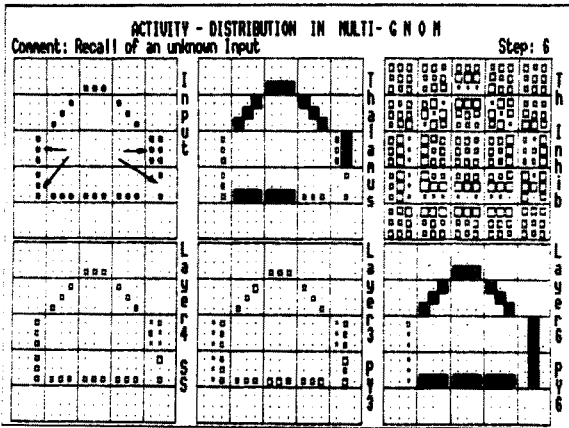

Fig. 4
 Processing of a "scene" by the columnar array (see text). The number of texture elements that could be synchronized define the position of this grouping within the sequence.

4. Conclusion

The results demonstrate the potential ability of a network composed of such type complex processing nodes for flexible scene interpretation. A simulation in a more realistic scale is required to prove this hypothesis on early visual processing.

5. References

- /1/ E. Koerner, I. Tsuda and H. Shimizu: "Take-grant control, variable byte formation and processing parallel in sequence-characteristics of a new type of holonic processor" in: "Parallel Algorithms and Architectures," A. Albrecht, H. Jung and K. Mehlich, Akademie-Verlag Berlin 1987
- /2/ G. L. Shaw, D. J. Silverman and J. C. Pearson: "Trion Model of Cortical Organisation: Toward a Theory of Information Processing and Memory". in: "Brain Theory," G. Palm and A. Aertsen (eds.) p. 177 - 92 Springer Verlag Berlin, Hdbg., NY, Tokyo 1986
- /3/ G. A. Orban: "Neuronal operations in the visual cortex". Springer Verlag Berlin, Hdbg., NY, Tokyo 1984
- /4/ P. M. Churchland: "Cognitive neurobiology: a computational hypothesis for laminar cortex". Biology and Philosophy 1, 1986, 25 - 51
- /5/ T. Winograd and F. Flores: "Understanding Computer and Cognition: A New Foundation for Design". Ablex, Norwood, NY, 1986
- /6/ F. Crick: "The function of the thalamic reticular complex: the searchlight hypothesis". Proc. Natl. Acad. Sci. USA, 81, 1984, 4586 - 90
- /7/ Y. Hirai: "A model of human associative processor (HASP)". IEEE Trans. Syst., Man and Cyb. SMC-13, 1983, 851 - 7